



FEATURES

- Replaces the Maxwell PC5
- 10 year life capability
- Hermetically sealed, stainless steel construction
- Low profile prismatic design
- Higher energy vs. electrolytic
- Higher power vs. batteries
- RoHS compliant

APPLICATIONS

- Automatic meter readers (AMR)
- Back-up power for last gasp and soft shutdown
- Wireless transmissions
- Handheld devices- commercial and military

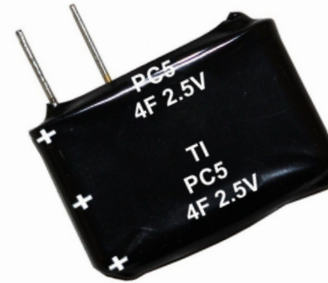

SPECIFICATIONS

Item		Performance	
Operating temperature		-40°C to +70°C	
Storage temperature		-40°C to +85°C	
Rated voltage		2.5 VDC	
Capacitance		4.0F	
Capacitance tolerance		±20%	
Endurance	1000 hr at 70°C at rated voltage	Capacitance change	Within ±20% of initial measured value
		Internal resistance	Within 2 times of initial specified value
Lifetime at 25°C	500,000 cycles	Capacitance change	Within ±20% of initial measured value
		Internal resistance	Within 2 times of initial specified value
Cycle life at 25°C	10 years @ 25°C at rated voltage	Capacitance change	Within ±20% of initial measured value
		Internal resistance	Within 2 times of initial specified value
Cycle: Between rated voltage and 1/2 rated voltage, constant current @ 25°C			



Units = mm

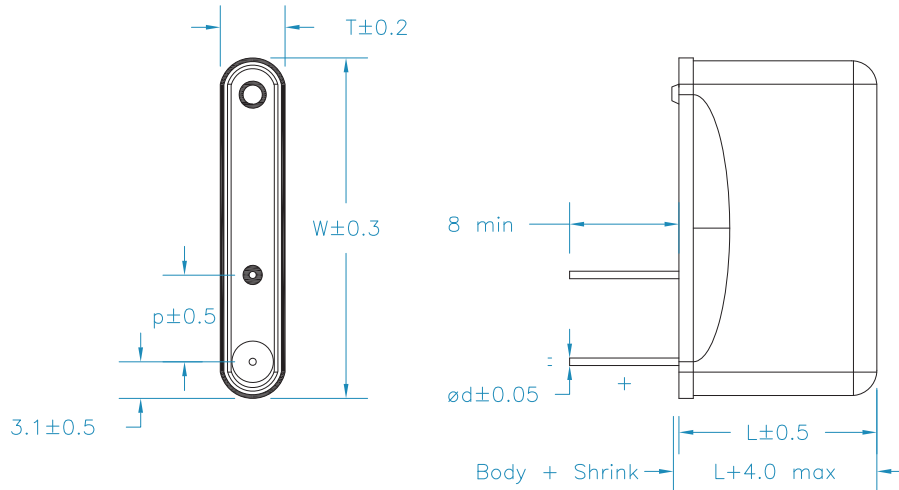

STANDARD PRODUCTS

Part Numbers	CAP. (F)	ESR/DC (mΩ)	ESR/AC 1kHz (mΩ)	Leakage Current (mA) (72 hrs @ 25C)	Size (mm)					Rated Voltage (VDC)	Typical Pkg. Qty.	Weight/unit (grams)
					L	W	T	d	p			
PC5	4.0	500	362	0.02	14	23.6	4.8	0.5	5.1	2.5	500	4