



USER MANUAL

Maxwell Technologies® BOOSTCAP® Energy Storage Modules for Heavy Duty Transportation Applications

**User Manual for 125 V Modules with CAN Communication
Protocol:**

- **BMOD0063 P125 B24 22**
- **BMOD0063 P125 B14 22**
- **BMOD0063 P125 B04 22**
- **BMOD0063 P125 B33 22**

Revision 5



WARNING**DANGER – HIGH VOLTAGE HAZARD!**

Never touch the power terminals as the module can be charged and cause fatal electrical shocks. Always check that the module is fully discharged before manipulating the module. Please refer to the step by step instructions in the Safety section of this manual for the manual discharge procedure.

WARRANTY LIMITATION

Do not open or modify the module. Opened or modified modules are no longer covered by warranty and are unserviceable property of the customer.

1. Introduction

The 125 V heavy transportation modules are self-contained energy storage devices comprised of 48 individual ultracapacitor cells. The modules include bus bar connections, and integral voltage management circuitry. Units may be connected in series to obtain higher operating voltages, parallel to provide additional energy storage, or a combination of series/parallel arrangements for higher voltages and energy. 125 V modules must never be connected to other types of modules in any way. Thermal monitoring and electronic voltage management circuitry is incorporated into each of the heavy transportation modules. The voltage management circuitry functions primarily to protect every cell from operating in a damaging over voltage condition.

The module is equipped with Maxwell Voltage Monitoring System. This system monitors the voltages of six (6) groups of 8 cell strings, as well as the temperature. The values of these measurements can be retrieved by CAN communication.

The heavy transportation module is built with heavy-duty extruded aluminum enclosures. The modules are cooled using two DC axial fans and two large, finned heat sinks which make up the top and bottom of the enclosure. Sheet metal shrouds make up the air passage and direct the cooling air over the heat sinks. The module is permanently sealed, water-resistant per IEC 60529 – IP65, and require no internal maintenance. The power terminals are fully enclosed in a water-resistant junction box. The low voltage CAN connectors, chassis vent, and earth ground stud are selected to be suitable for heavy transportation environments.

2. Unpacking

Inspect the shipping crate for signs of damage prior to unpacking the module. Damage to the shipping crate or module should be reported to the carrier immediately.

Remove the module from the shipping crate by removing the lag screws and lifting the module straight up by the lifting handles or lifting brackets. The 125V module weighs 56 kg without accessories and fans and can be lifted by hand by two people. Please refer to figure 3.2 for handles and bracket locations

Retain the shipping materials until the unit has been inspected and is determined to be operational. The

original shipping materials are approved for both air and ground shipment. Make sure that the shipping container(s) contains the following:

1. Heavy Transportation Module
2. Accessory Box
 - a) Fan Shroud Assembly (12V or 24V)
 - b) Accessory Kit (including junction box)
3. User Manual

If the unit is found to be defective or any parts are missing, contact the factory. A Return Material Authorization (RMA) number must be issued prior to returning the unit for repair or replacement.

3. Installation

3.1. Mechanical

The heavy transportation modules can be mounted in multiple orientations and requires the proper hardware to be used. Good, high voltage electrical practices should be observed in design of the module installation. The supported orientations are:

- Horizontal, straight.
- Vertical, on the longer side. For this orientation, the module needs to be bolted to a supporting wall or structure.
- Any angle between horizontal, straight and vertical, on the longer side. The module must be properly bolted to a supporting structure and the top of the module must face upward.

The mounting surfaces on the bottom angles are designed to support the module with no additional mechanical contact. Fasteners must be Class 12.9 or stronger, must be torqued properly, and must include flat washers and locking devices. The following fasteners (not supplied) are recommended for attaching the modules to the vehicle: 4 screws, M8 -1.25 x 20 mm long. Please note that longer screws may be required if using through-holes and nuts.

Note: Maxwell Technologies specifications and warranty apply only when mounting the module using the feet as assembled at the factory. Removal of the feet and mounting directly to the body of the module voids the warranty. Should the module be mounted without the factory supplied feet (mounting points are detailed in document 1014553, available by download at <http://www.maxwell.com>), the user is required to provide shock and vibration test data to re-validate the warranty.

Refer to Figures 3.1, below for overall module dimensions, mounting envelope, and mounting hole locations. The use of alternate module mounting orientations or custom feet other than those provided by Maxwell Technologies will result in voiding the warranty unless such uses have been disclosed to Maxwell and approved by Maxwell by express written consent prior to implementation. Zones 1 (inlet) and 2 (exhaust) are reserved for cooling air. One of the sides A, B, or C must be completely unobstructed and adjacent to ambient air on both the inlet and exhaust sides of the module.

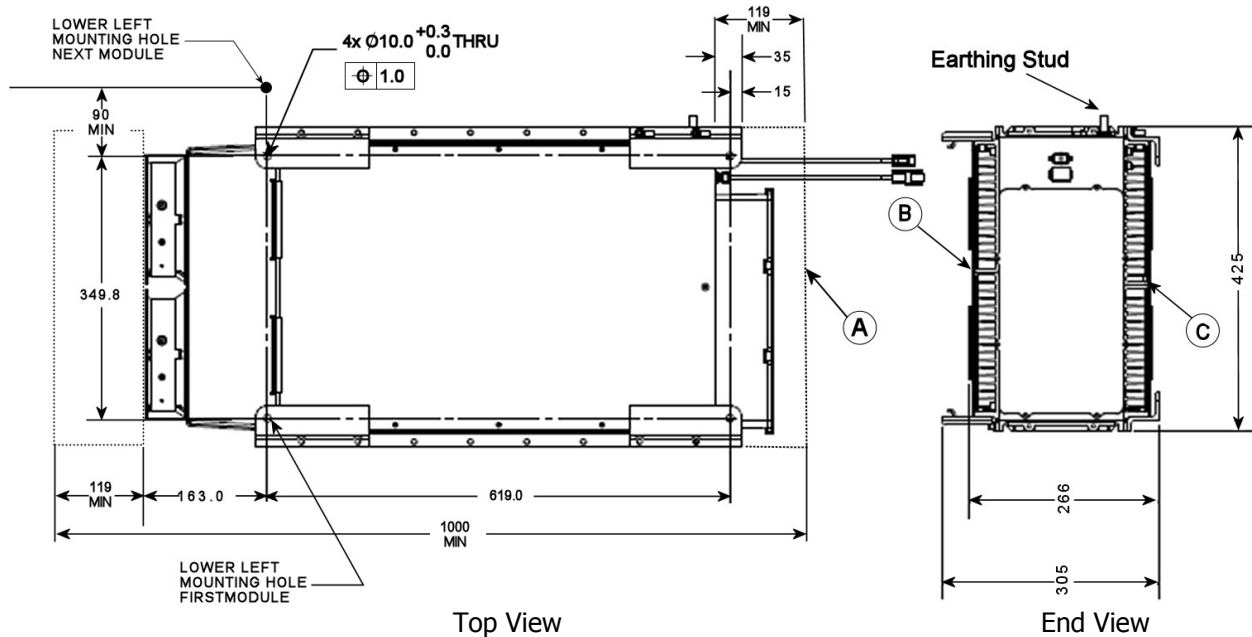

Figure 3-1. 125 V Installation Dimensions. One of the sides A, B, or C must be completely unobstructed and adjacent to ambient air on both the inlet and exhaust sides of the module. (CANBus cables are not to scale.)

The 125 V module is installed onto the vehicle first, then the fan shroud assembly is installed onto the module with screws provided. The handles may then be removed if desired. Refer to Figures 3.2 for exploded views of the modules and fan shroud assemblies. Re-assembly of the fans in the opposite direction in order to provide reversed air flow is at this point neither recommended nor supported.

Note: The mounting envelope is specified in order to provide adequate space for cooling air to enter and exit the module. Failure to provide space for cooling air will cause the module to operate at a higher temperature and, therefore, reduce the life of the capacitors. Additional minimum space of 66mm will also be required in front of the module to allow for the high power electrical cables. Flexible electrical cable (such as finely stranded or welding cable) must be used to achieve the necessary bend radius. If stiffer cable is used, additional clearance will be required in front of the module.

When installing multiple modules in series or parallel configurations refer to Figures 3.1 for proper hole spacing. Modules may be stacked vertically only if attached to individual support structures. Leave 25mm clearance (minimum) between modules. Refer to section 3.2.1 for electrical information on series and parallel configurations.

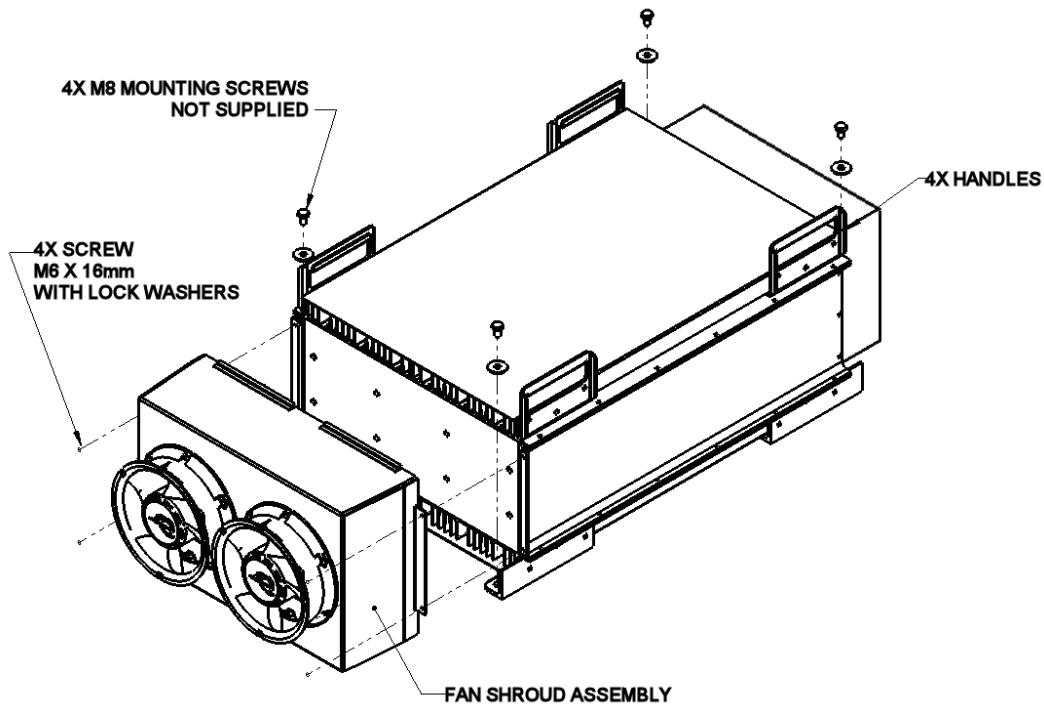



Figure 3-2. 125 V module with fans (not included with model B04).

3.2 Electrical

WARNING
 DANGER
To avoid arcing and sparking the energy storage module should be in a discharged state and the system power disconnected during installation. The module is shipped discharged and with a shorting resistor wire. The shorting wire should be removed just prior to making electrical connections. For more information about the discharge procedure please refer to section 7, Safety.

To provide the lowest possible equivalent series resistance (ESR) the high-power current path within the heavy transportation module is not fused. Care should be taken within the application to prevent excessive current flow as required. Excessive current and/or abnormal duty cycle will result in overheating the module which will cause irreparable damage. Please consult the specific data sheet for each module for current and duty cycle capabilities.

Note: The chassis of the module must be connected to system ground through the earthing stud (size M10-1.25, located on right side of the module, see figure 3.1) with large enough gauge wire to carry the worst-case fault current, or directly through the mechanical mounting points and into the vehicle chassis. Customer should supply a nut with these threads and also use of a lock washer is recommended.

3.2.1 High Power Connection

The high power electrical connections are made within a sealed junction box mounted to the front of the module. The connectors also use proprietary Radsok® contacts which provide low insertion force and reliable low resistance capability. These connectors must be mated with the correct Amphenol lugs, available in the accessory kit (see Section 5 for part numbers). The mating connectors accept cables with a maximum conductor OD of 11.1mm (90 degree connector) or 9.1mm (straight connector). If using another size, the cable should have the correct size & temp rating for the application current. Cables which are too small can add a significant amount of resistance to the installation, reducing system efficiency and generating heat. The following steps need to be taken in order to properly assemble the junction box and power connections:

- 1) Unpack the accessory kit.
- 2) Using a holesaw (not provided) with the proper diameter, drill both cable holes at the desired location on the junction box housing or junction box lid. Maxwell provides 2x M25 fittings but diameters up to M32 can be supported by the junction box. The 2 holes can be on any of the 4 sides or on the lid of the junction box depending on the customer's implementation in vehicle.

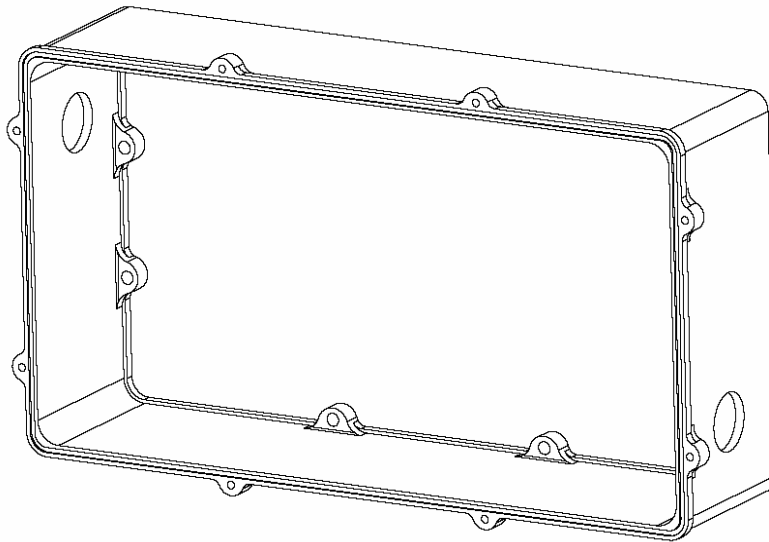

Figure 3-3. Junction box with 2 holes. Holes may be drilled on any side or on the cover.

- 3) Install the 2x M25 fittings in the holes.

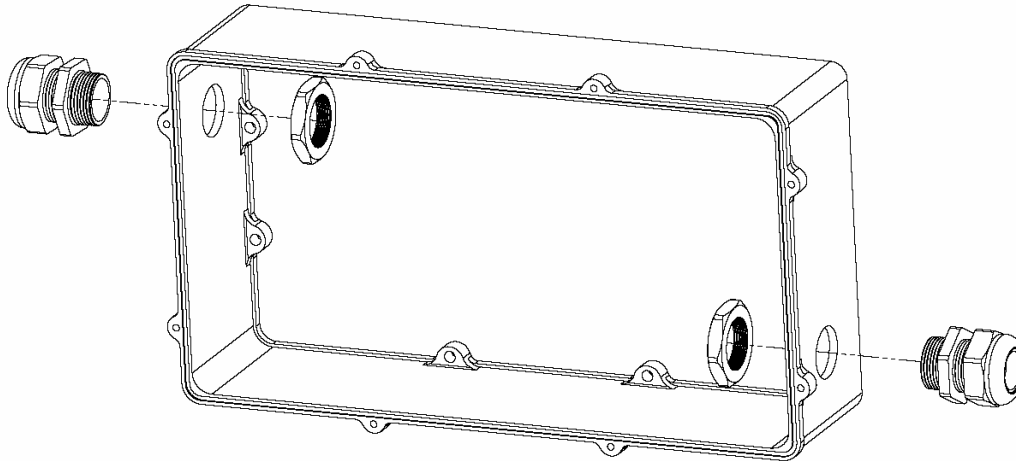

Figure 3-4. Fittings assembly.

- 4) Trim the power cables (not provided) to the appropriate lengths.
- 5) Install the junction box housing and fasten it to the front panel using the 8x M5 screws and #10 washers with a 6 N-m torque. Apply Loctite 271 (provided) to the screws before installing.

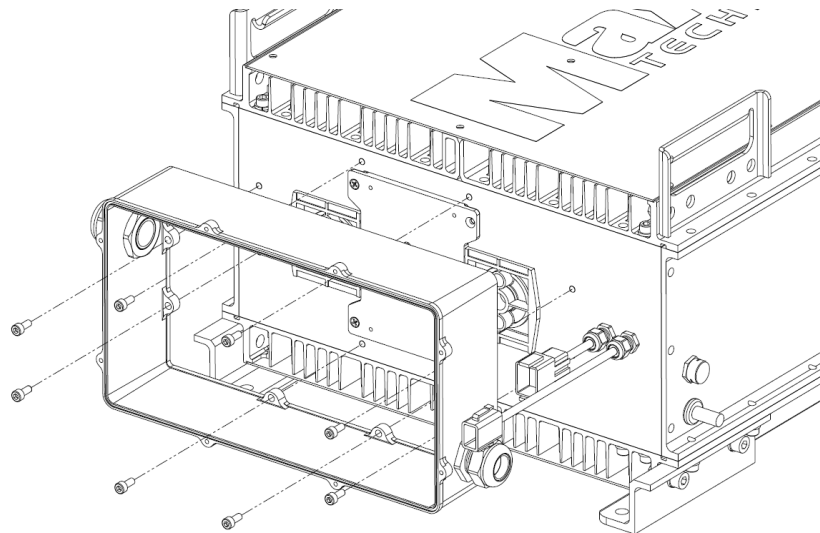

Figure 3-5. Junction box assembly on the module. (CANBus cables not to scale.)

- 6) Insert both cables into the junction box through the fittings.

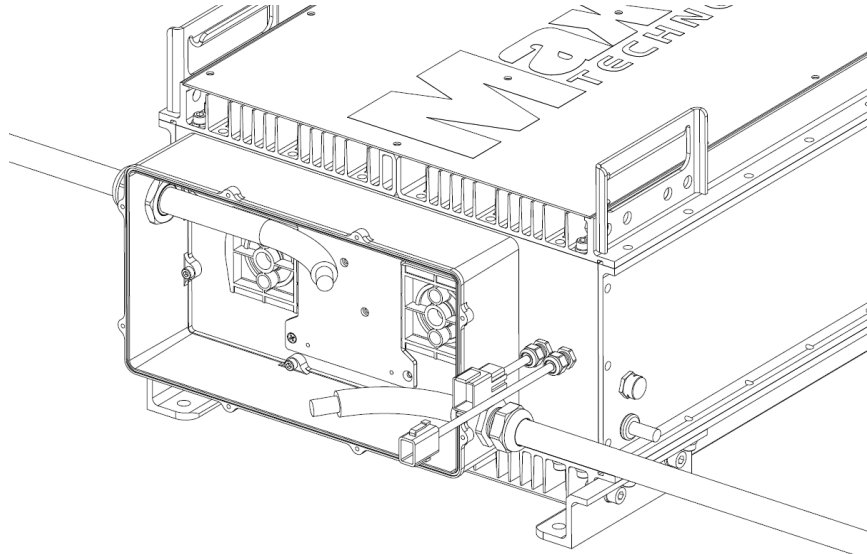

Figure 3-6. Customer cables insertion in the junction box. (CANBus cables not to scale.)

- 7) Install the 90° swivel adapters at both terminal locations on the front panel of the module. Swivel adapters are required to accommodate variation in cable lengths and allow mechanical relief of the assembly. This step is not required for front installation.

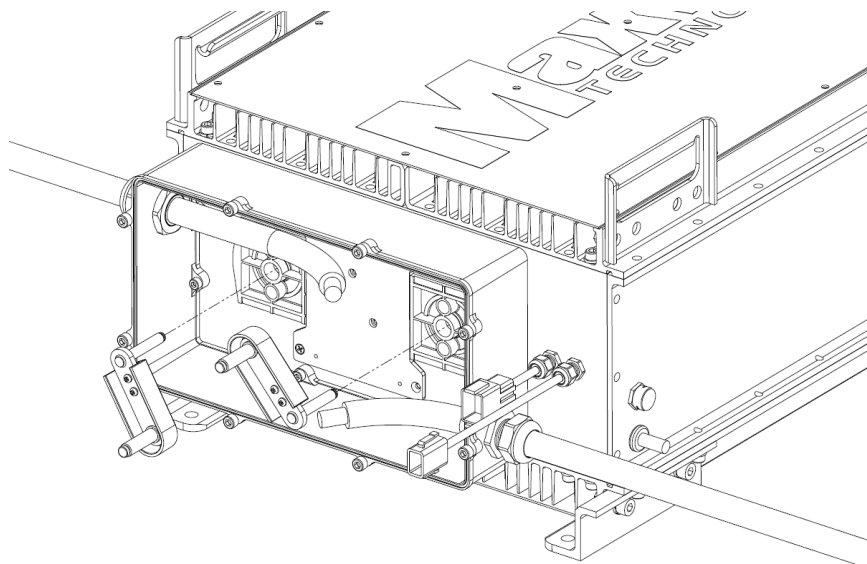

Figure 3-7. Swivel adapters insertion in the junction box. (CANBus cables not to scale.)

- 8) Crimp the lugs onto both cables. When connecting multiple units together, make sure that both ends of the cables are installed in both junction boxes prior to crimping.
- 9) Depending on the location of holes, creepage and clearance distances between the 2 terminals

may be too short and require extra isolation. To maintain the proper creepage distance for an operating voltage of 1000V, we recommend at least 19.1 mm through air. For this purpose, install and clip the plastic covers around both cable lugs. This step is not required for front installation.

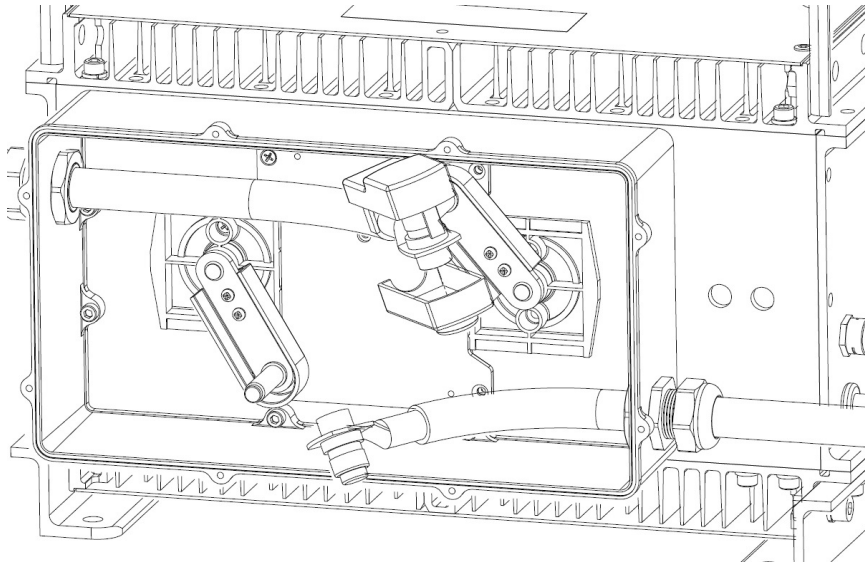

Figure 3-8. Swivel adapters cover assembly. (CANBus cables not shown.)

- 10) Connect both power cable lugs to the respective terminal pins by pressing them in all the way.

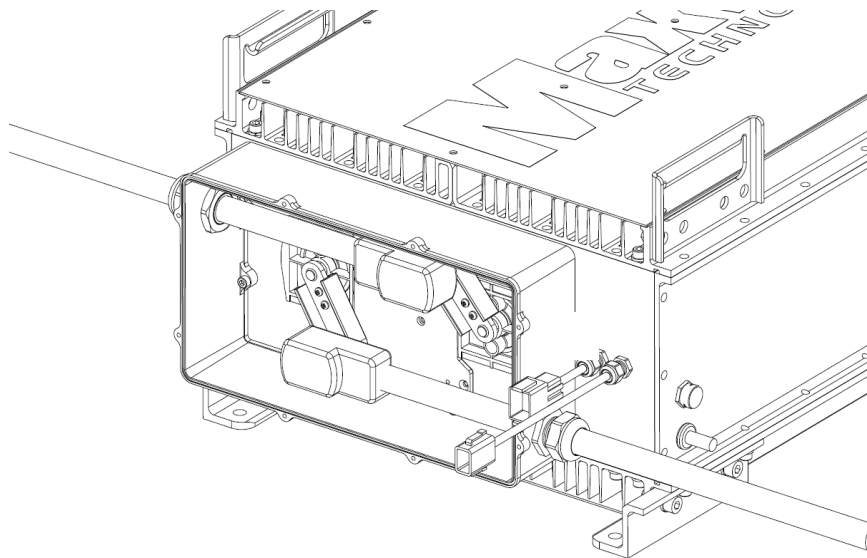

Figure 3-9. Final connector assembly. (CANBus cables not to scale.)

- 11) For the side assembly, tighten the 2 fittings to ensure proper stability and water resistance of the assembly. For the front assembly, it is recommended to measure the length of the section of cables inside the junction box to make sure they will properly fit and provide enough slack. Then unplug the pin power connectors, tighten the 2 fittings and re-plug the pins at both power terminal locations.

Alternately, for multi module implementations with short cables, the junction box can be mounted on the module after cable insertion, fitting and crimping.

- 12) Install the lid and tighten the 4x M4 screw and washers with a torque of 3 Nm. Apply Loctite 271 (provided) to screws before installing.

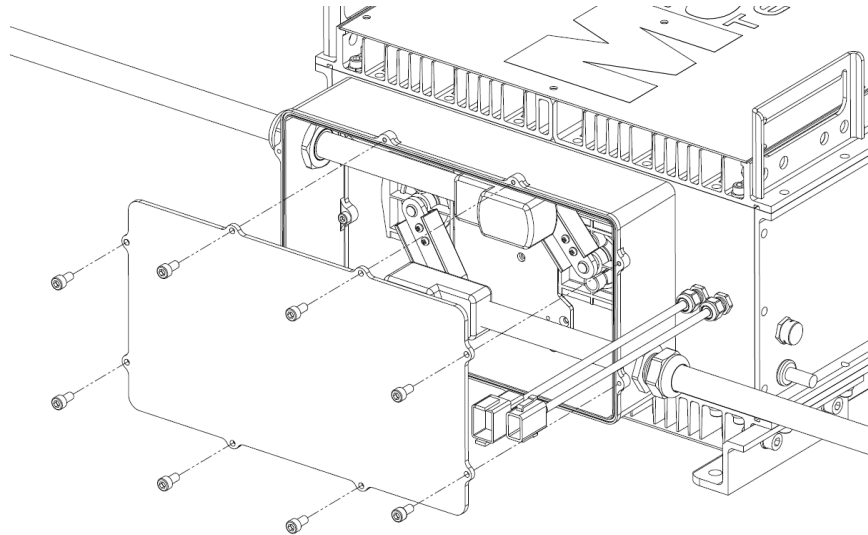

Figure 3-10. Lid assembly on the junction box. (CANBus cables not to scale.)

Connection of modules in series or parallel should be done with the same gauge wire as determined for final output connections. When connecting in series connect the positive output terminal of one module to the negative output terminal of the next module. Parallel arrangements require tee connections in the cable (not supplied).

Up to twelve (12) 125 V modules may be connected in series for high voltage applications. This corresponds to a maximum system voltage of 1500 VDC. Isolation of the modules is tested to 4000 VDC. The modules should not be used in higher voltage environments. If higher voltage is desired, please contact your Maxwell representative. When several modules are connected in series for operating at higher voltage, care must be taken to ensure proper creepage and clearance distances in compliance with national safety standards for electrical equipment.

3.2.2 CAN Monitor – Configuration B04/B14/B24

CAN Bus communications protocols, data formats and commands are covered in a separate manual. For a detailed description of the communication protocol, please refer to the document “Maxwell Technologies CAN Communication Specification” (document number 1014339). The latest version may be found at <http://www.maxwell.com>.

3.2.2.1 Connection

The HTM125 Ultracapacitor Module is equipped with two 8 pin Deutsch connectors each on a short cable. One of the connectors is a Socket Plug and one is a Pin Receptacle for easy daisy chaining.

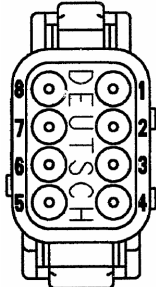
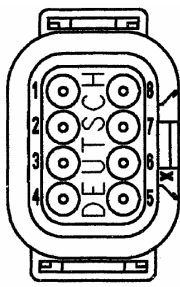
Connector Type	Socket Plug	Pin Receptacle
Drawing Overview		
Connector PN	DTM06-08SA	DTM04-08PA
Wedgelock PN	WM-8S	WM-8D
Socket / Pin PN	0460-202-20141	0462-201-20141

Connector Pin Out

Description	Pin
CAN_H	1
CAN_L	2
SHIELD	3
NC	4
NC	5
NC	6
24 RTN	7
24 VDC	8

3.2.2.2 Voltage Monitoring

The CAN Monitor measures the voltage from the negative terminal to every 8th cell and transmits the values over the CAN bus to the network master. For a detailed description of the communication protocol, please refer to the document "Maxwell Technologies CAN Communication Specification" (1014339). The latest version of the communication protocol and this manual can be downloaded at <http://www.maxwell.com>.

Every pack will have a unique separation of voltages across the 8-cell string due to differences in cell capacitances, interconnect resistance variances, and other native cell contributions. Therefore, the pack should be measured for its baseline condition, which should have a variance of less than 3 V when first energized after the module is received from the factory. The difference in the 8-cell string voltages should be regularly monitored during use as it can be used as a performance indicator for that module. If the voltage across any two 8-cell strings diverge from each other over use and time such that the voltage difference is greater than 3V, the monitor sends a warning flag via the CAN bus. When this happens, a reconditioning cycle should be applied in order to bring the strings back into better balance.

When multiple (N) modules are connected in series, the voltages of all 8 cell strings (N x 6 measurements) should be monitored through the CAN communications.. Calculate the difference between the maximum string voltage measured and the minimum string voltage measured. This difference is the Peak Delta Voltage for the system (This is different than the Peak Delta Voltage which can be read through CAN communication as the direct reading is the difference only within a particular

module.). It should be compared to the table values below. If the difference in voltages exceeds the table value, a reconditioning cycle should be performed.

Series Connected Reconditioning Triggers

Number of Modules in Series	Peak Delta Voltage Trigger
1	3.0V*
2	
3	
4	
5	
6 to 12	2.6V

* This is the value which sets the flag in CAN communications for each module.

The reconditioning cycle is the following:

1. Charge the series of modules to 129.6 V x Number of Modules in Series for 5 minutes. Monitor the 8-cell string voltages and the Peak Delta Voltage as reported via the CAN bus.
2. Disable/Disconnect the charging source. Ensure that no leakage current occurs between the charging source and the module.
3. Monitor the 8-cell string voltages and peak delta voltage using the CAN bus. The voltage management circuits will work to reduce the cell voltage. Check the peak delta voltage when each module voltage has drained to about 125 V or when the total voltage across all series connected modules is Nx125V. This should take about 10 – 15 min. If the peak delta is now lower than 1 V, the reconditioning is finished and the module can be put back in operation. If the peak delta voltage is larger than 1V, redo the reconditioning cycle from point 1 above.

In the chance event that the voltages do not converge during the reconditioning cycle the active balancing electronics is not functioning correctly. Please contact your Maxwell application/sales engineer for further assistance.

3.2.3 Analog Monitor – Configuration B33

WARNING
 <p>DANGER – HIGH VOLTAGE HAZARD!</p> <p>Never touch any of the tap pins as the module can be charged and cause fatal electrical shocks.</p> <p>Always check that the module is fully discharged before manipulating the module. Please refer to the step by step instructions below for the manual discharge procedure.</p>

3.2.3.1 Connection

A single, 5-pin connector on the front panel of the heavy transportation modules carries signals for temperature monitoring and center-tap voltage monitoring. Figure 3-11 shows the pin assignment on the 5-pin, 7KVA, panel mounted monitoring connector of the 125 V module.

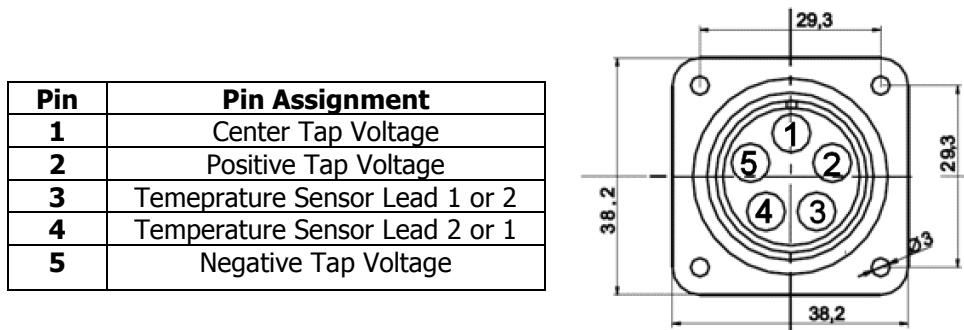
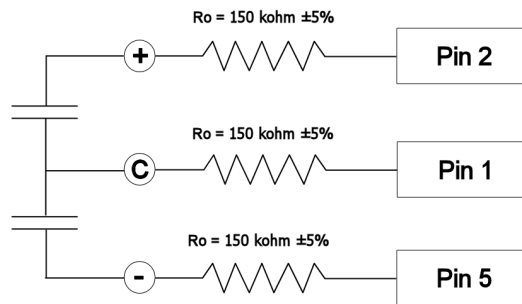

Figure 3-11: Pin assignment for 5-pin, module panel mounted monitoring connector

3.2.3.2 Voltage Monitoring

The 125 V modules use 3 pins in the 5-pin connector for positive (pin 2), negative (pin 5) and center-tap (pin 1) voltage monitoring. The center-tap voltage is a monitoring capability that provides an indication of relative distribution of cell voltages in the module, separated into two halves. In design of the corresponding measurement circuit, the output impedance of these monitoring connections should be taken into account. The output impedance provides a safety margin. In case of a short to ground, the maximum current will be than 10mA.



$$V_{total} = V_{m1} + V_{m2}$$

Where:

V_{total} is the measurement from the positive input to the negative output of the module

V_{m1} is the measurement from the positive input to the center tap.

V_{m2} is the measurement from the center tap to the negative output.

It is recommended that the measurement circuit have an input impedance of at least 100 times the output impedance of the device being measured. If the input impedance is lower than this, a scaling factor will need to be applied.

$$V_{\text{output}} = V_{\text{measured}} \times [(R_{\text{input}} + R_{\text{output}}) / R_{\text{input}}]$$

Every pack will have a unique separation of the two halves due to differences in cell capacitance, interconnect resistance variances, initial state of charge separations, native cell leakage current variations and other known contributions. Therefore, the pack should be measured for its baseline condition, which should have a variance of less than 4 V when first energized after the module is received from the factory. The difference in the half pack voltages should be regularly monitored during use as it is a performance indicator for that module and may change as the module ages. A monitoring frequency of once per day would be sufficient (may be less frequent depending on the application). Little value will be gained by monitoring more frequently. If the two halves of the pack diverge from each other over use and time such that the voltage difference between halves is greater than 6V, a reconditioning cycle should be applied in order to bring the halves back into better balance. The reconditioning will not only bring the halves back to balance but also can help determine the cause of this divergence. The reconditioning cycle is the following:

Charge the module to 129.6 V (or the module string to 129.6V x number of modules in series) and hold on charge for 5 minutes. At this time measure the half pack voltages. Given effective working voltage management circuitry, the half pack voltages will be below the 4 V maximum range after conditioning. If that is not the case, contact your applications engineer for further information. If that is the case, then the module can be put back into service. Monitoring of the half pack voltages can then resume as was the case before exceeding the 6 V limits. Assuming the rate of change of the two half pack voltages is similar to what it was before the conditioning process was performed, the indication is that the module is functioning normally. Excessive divergent voltage rates in the halves or step functions in the half pack voltages which cause them to separate will indicate possible defect conditions in the pack.

A 5-pin mating connector for the monitor output is provided as part of the accessory kit (see Section 5 for part numbers). 22 gauge wire may be used to make cables up to 6 feet (1.8 m) in length. For lengths longer than 6 feet (1.8 m) shielded wire is recommended.

3.2.4 Temperature Monitoring

3.2.4.1 Temperature Sensors

The 125 V module uses a temperature sensor within the module at a location which is representative of the cell population temperature. See Figure 3-12 for a diagram of the temperature sensor location on the 125 V module.

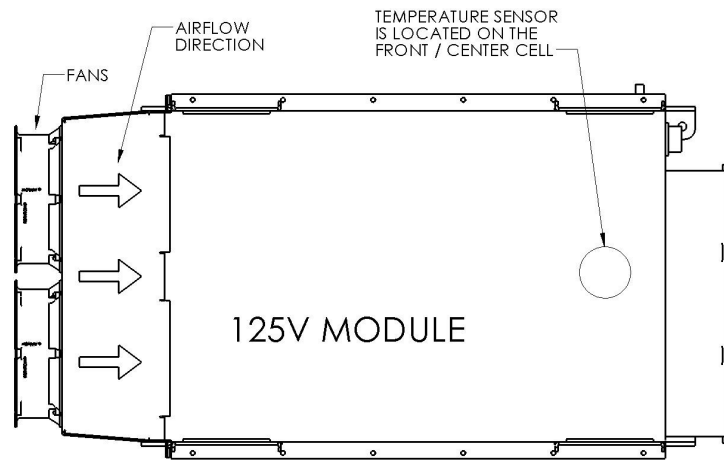

Figure 3-12. Temperature Sensor Diagram for the 125 V Module

3.2.4.1.2 Digital Monitoring

The CAN Monitor measures the temperature and sends the value over the CAN bus to the network master. The CAN Monitor also compares the measured temperature to pre-set warning and alarm levels. If the temperature is outside of the operating range, a flag will be set as an indication to the master. For detailed description of the communication protocol please refer to the document "Maxwell Technologies CAN Communication Specification" (document number 1014339).

3.2.4.1.2 Analog Monitoring (Configuration B33)

The temperature output is via a PT100 RTD temperature sensor. The resistance of the RTD varies with temperature to provide actual temperature of the module. The resistance measured through the RTD relates to temperature according to the temperature chart in table 1.4 for the Minco resistance S17624PDYT15BC (EN60751, Class B, 100 Ohm @ 0°C) <http://www.minco.com>.

Table 3.13 RTD function diagram for the 125 V Module

3.2.4 Fan Connection

The 125 V modules are cooled by two 12 V or 24 V DC axial cooling fans. The fans each have two 30.5mm, 22 gauge (0.64mm) wires for electrical interconnection. (red = positive, black = negative). The wires are un-terminated to allow for maximum customer flexibility in providing power and connection to the fans. The fans can draw up to 2.3A each.

4. Thermal Considerations

Low internal resistance of the energy storage modules results in relatively low internal heat generation within the modules during use. However, the high demands of heavy transportation warrant the use of heat sinks and cooling fans to keep the cells at a low, uniform temperature. Operating the module at a temperature above 65°C will void the module warranty. As with all electronic components, ultracapacitors have a longer service life when kept at a lower temperature. The thermal resistance, $R_{th,r}$ of the units has been experimentally determined assuming forced convection at ambient (~ 25°C). The R_{th} value provided on the data sheet is useful for determining the operating limits for the units. Using the R_{th} value

a module temperature rise can be determined based upon any current and duty cycle. The temperature rise can be expressed by the following equation:

$$\Delta T = I^2 R_{esr} R_{th} d_f$$

Where:

I = current (amperes)

R_{th} = thermal resistance (°C/W)

R_{esr} = resistance (ohms)

d_f = duty cycle fraction

This ΔT plus ambient should remain below the specified maximum operating temperature for the module as measured by the RTD output.

5. Accessories

The accessory kit is included with 125 V heavy transportation modules and contains the following:

Part Number	Description	Quantity
107686	M18 fittings	2
107687	M18 fittings, Nuts	2
107941	Power terminal male/male swivel adapters	2
108585	Male pin/female crimp power connectors	2
107690	Lug connectors, with plastic isolation cover	2
107940	Junction box with seals	1
107642	Junction box lid	1
108222	Connector, 8-pos plug, DTM*	1
108223	Connector, 8-pos rec, DTM*	1
108230	Wedgelock for DTM06*	1
108231	Wedgelock for DTM04*	1
104995	Contact, solid, pin, Deutsch*	5
104998	Contact, solid, socket, Deutsch*	5
107693	Screw, TORX, M4-0.7x10mm, Zinc Plated	8
107990	Screw SHCS, M5-0.8X20, CLASS 12.9, Plated	8
106583	Washer, Lock, #10, SS	8
106775	Washer, Lock M4, SS	8
107993	Loctite 271	1
107728	Mating Monitor Connector **	1

* CAN version (B04, B14, B24) only.

** Analog version (B33) only.

6. Operation

The heavy transportation modules should only be operated within specified voltage and temperature ratings. Determine whether current limiting is necessary on input/output based on current ratings of ancillary devices. Observe polarity indicated on module.

7. Safety

WARNING

DANGER – HIGH VOLTAGE HAZARD!
Never touch the power terminals as the module can be charged and cause fatal electrical shocks. Always check that the module is fully discharged before manipulating the module. Please refer to the step by step instructions below for the manual discharge procedure.

- Do not operate unit above specified voltage.
- Do not operate unit above specified temperature rating.
- Do not touch terminals with conductors while charged. Serious burns, shock, or material fusing may occur.
- Protect surrounding electrical components from incidental contact.
- Provide sufficient electrical isolation when working above 50 V DC.
- Prior to installation on and removal from the vehicle or equipment, it is mandatory to fully discharge the module to guarantee the safety of the personnel.

WARNING

A fully discharged module may “bounce back” if it is stored without a shorting wire connected to the + and – terminals. This bounce back can be as much as 15V for the 125V module, and is enough to cause dangerous electrical shocks.

Proceed as follow to discharge the module:

1. Using a voltmeter, measure the voltage between the 2 terminals.
2. If the voltage is above 2V, a resistor pack (not supplied with the module) will need to be connected between the terminals. Proper care needs to be taken in the design and construction of such a dissipative pack. *e.g.* At 125V, for a 4 Ohm pack, the module will be discharged with a current of 31.25A and will take about 20 minutes to fully discharge. However, in this case, the heat/power dissipated in the resistor pack will be ~ 3.9kW. The resistor pack will need to be sized and provided with suitable cooling to handle this power dissipation. Additionally, proper enclosure or other packaging is necessary to ensure safety. In all cases, proper design of the dissipative resistor pack is necessary.
3. If the voltage is under 2V, connect the shorting wire provided by Maxwell to the + and – connectors.
4. The module is now safe for handling. However, leave the shorting wire connected **at all times** until the module is installed in the vehicle the power cables are connected.

8. Maintenance

Prior to removal from the vehicle, cable removal, or any other handling ensure that the energy storage module is completely discharged in a safe manner. The stored energy and the voltage levels may be lethal if mishandling occurs.

8.1. Fan Maintenance

The 125 V module uses Orion fans - model OD172SAP-24HBXC-55 (24 V) or OD172SAP-12HBXC-55 (12 V). The expected life of the fans (based on L10 life) is 65,000 hours at 45°. L10 life is defined as the time when 10% of the sample could be expected to fail. The customer is responsible for monitoring fan operation, if desired. It is recommended to monitor cell temperature as an indication of fan performance. Damage to cells as a result of fan failure is not covered under warranty.

8.2. Module Conditioning

Please refer to section 3.2.2.2.

9. Storage

The module can be stored in the original package discharged in a dry place. Observe the maximum storage temperature as stated in the specifications. Discharge used module prior to stock or shipment. The shorting wire shipped with the unit should be retained for use during storage to prevent charge from accumulating in the module.

10. Disposal

Do not dispose of module in trash. Dispose of according to local regulations.

11. Specifications

Refer to data sheets for specifications for each specific product.

Contact Information

**Maxwell Technologies,
Inc.
Worldwide Headquarters**
9244 Balboa Avenue
San Diego, CA 92123
USA
Phone: +1 858 503 3300
Fax: +1 858 503 3301

Maxwell Technologies SA
CH-1728 Rossens
Switzerland
Phone: +41 (0)26 411 85 00
Fax: +41 (0)26 411 85 05

**Maxwell Technologies
GmbH**
Brucker Strasse 21
D-82205 Gilching
Germany
Phone: +49 (0)8105 24 16 10
Fax: +49 (0)8105 24 16 19

**Maxwell Technologies, Inc. -
Shanghai Representative
Office**
Rm.2104, Suncome Liauw's Plaza
738 Shang Cheng Road,
Pudong New Area
Shanghai 200120, P.R. China
Phone: +86 21 5836 5733
Fax: +86 21 5836 5620

info@maxwell.com – www.maxwell.com