

CLASS 1 SERIES (T.C. TYPE) NPO, N150, N1500, SL

CAPACITANCE

Test Frequency: 1MHz \pm 100KHz for <1000pF.
1KHz \pm 100Hz for >1000pF.

Test Voltage: Shall not exceed $1 \pm 0.2V_{rms}$.

Test Temperature: $25^{\circ}C \pm 2^{\circ}C$.

APPLICATIONS

- Resonant circuit.
- High Q requirement.
- High stability capacitor characteristics.

DISSIPATION FACTOR

< 0.1 @ $25^{\circ}C$.

QUALITY FACTOR (Q)

For NPO to SL: When $C < 30pF$, $Q = 400 + 20 \times CpF$; When $C > 30pF$, $Q > 1000$.

For C: above 1000pF @ 1KHz DF 0.2% maximum.

INSULATION RESISTANCE

10000M Ω minimum. Shall be measured after 1 minute at rated voltage.

DIELECTRIC WITHSTANDING VOLTAGE

Capacitors shall withstand, for not less than 1 second, a D.C. test.

Voltage of 3 times rated working voltage for $\leq 1KV$.

CLASS 2 SERIES (HL-K TYPE) Y5F, Y5P, Z5U

CAPACITANCE

Test Frequency: 1KHz

Test Voltage: $1 \pm 0.2V_{rms}$.

Test Temperature: $25^{\circ}C \pm 2^{\circ}C$.

APPLICATIONS

- By-pass and coupling.
- Frequency discriminating where "Q" and stability of capacitor characteristics are not of major importance.

DISSIPATION FACTOR

The DF shall not be greater than 2.5% for Y5E, Y5P & Z5U.

The DF shall not be greater than 5% for Y5V & Z5V.

INSULATION RESISTANCE

7500M Ω minimum. Shall be measured after 1 minute at rated voltage.

DIELECTRIC WITHSTANDING VOLTAGE

Capacitors shall withstand, for not less than 1 second, a D.C. test.

Voltage of 2.5 times rated working voltage.

CLASS 3 SERIES (S.C. TYPE) Y5R, Y5T, Y5V

Smaller sizes than Class-2, but lower "Q".

CAPACITANCE

Test Frequency: 1KHz @ $25^{\circ}C \pm 2^{\circ}C$.

Test Voltage: Not greater than $0.1V_{rms}$.

APPLICATIONS

- Transistorized.
- Low voltage electronic circuits for by-pass coupling.

DISSIPATION FACTOR

DF shall not exceed 5% for Y5P, Y5U, Y5V series.

INSULATION RESISTANCE

3.0VDC - 0.004M Ω - MFD. 10VDC ~ 12VDC - 0.04M Ω - MFD.

16VDC ~ 24VDC - 0.10M Ω - MFD. 25VDC ~ 50VDC - 100M Ω - MFD.

Dielectric withstanding voltage for less than 1 second at a test voltage of 2 times rated working voltage.

CAPACITANCE TOLERANCE

Code	Tolerance Value	Apply T. C.	Remark
C	±0.25pF	NPO - N750	For smaller than 5pF.
D	±0.5pF	NPO - N750	For smaller than 5pF.
F	±1pF	NPO - N750	For smaller than 5pF.
J	±5%	NPO - N1000	For over 5pF.
K	±10%	NPO - N1000 (Y5E, Y5P)	For over 5pF.
M	±20%	Y5U, Z5U (Y5E, Y5P)	For over 100pF.
S	+50%, -20%	Y5U, Z5U, Z5V	
Z	+80%, -20%	Y5U, Z5U, Z5V	
P	+100%, -0%	Y5U, Z5U, Z5V	

TEMPERATURE COEFFICIENT CHART

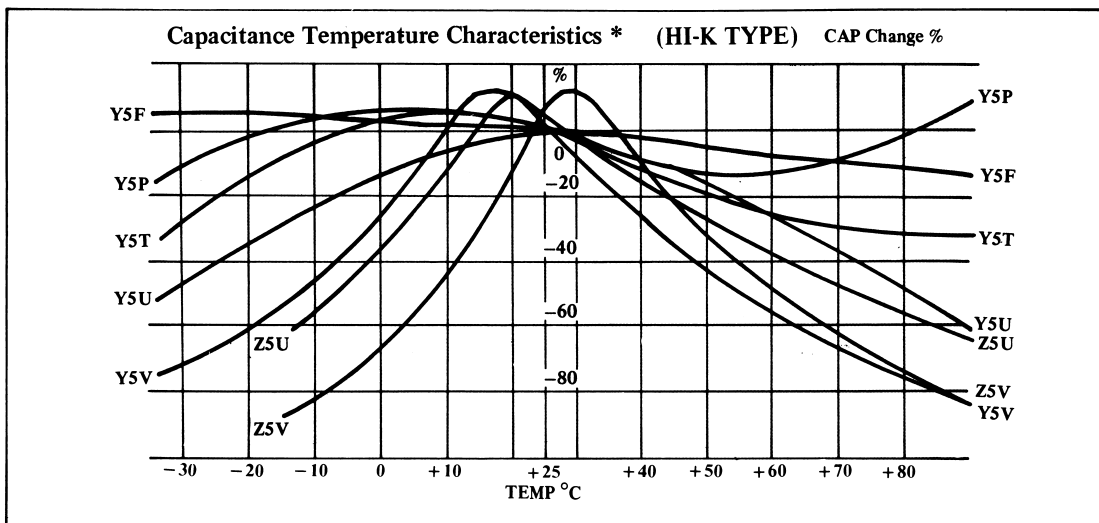
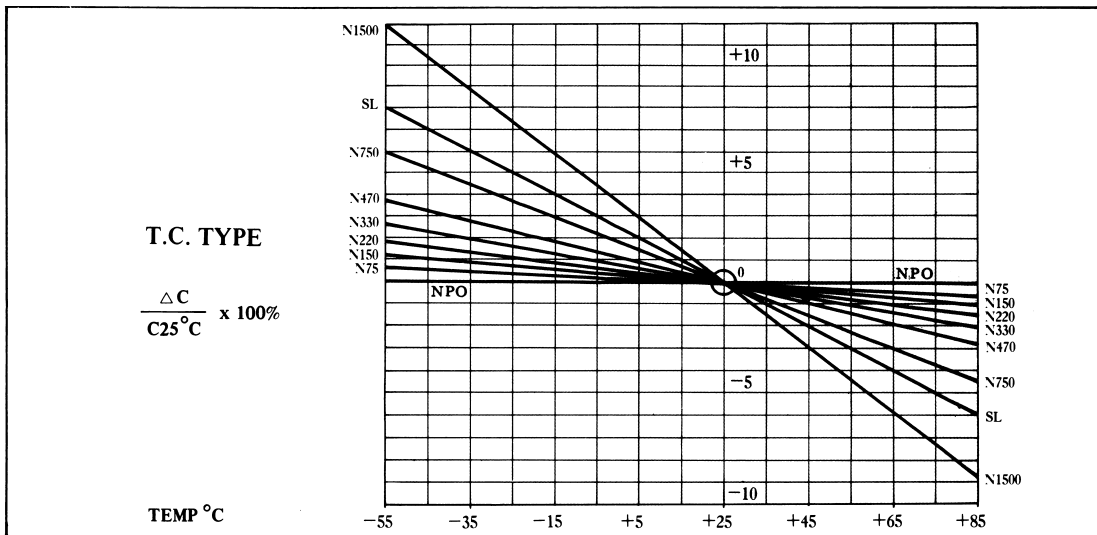

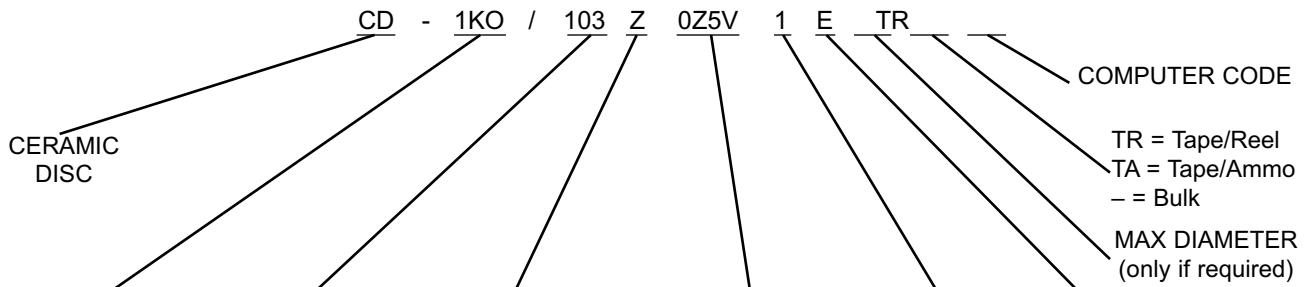

Rated Voltage	Nominal Capacitance	Standard Tolerance	Temperature Coefficient
-012 -016 -025 -050 -100 -250 -500 -1K0 -2K0 -3K0	First two digits are significant, third digit is the number of zeros to be added. 103 = 10,000pF = 0.01uF 1R0 = 1pF 3R3 = 3.3pF 100 = 10pF 220 = 22pF 101 = 100pF 221 = 220pF 102 = 1000pF 222 = 2200pF 103 = 0.01μF 223 = 0.022μF 104 = 0.1μF 224 = 0.22μF	F = ±1% J = ±5% K = ±10% M = ±20% Z = +80, -20% P = +100, -0% (G.M.V.) B = ±0.1pF C = ±0.25pF D = ±0.5pF	OPERATING RANGE Class II & III First Digit Second Digit Third Digit LOW HIGH %Δ temp temp cap. Z+10°C 4+65°C F ± 7.5 Y-30°C 5+85°C P ± 10 X-55°C 6+105°C R ± 15 7+125°C S ± 22 T+22 OPERATING RANGE Class I -30°C to +85°C NPOØN1500 SL (N330 ± 500ppm)

Lead Spacing		
	mm	(in)
A	2.5	(0.1)
B	5.0	(0.2)
C	6.35	(0.25)
D	7.5	(0.3)
E	9.5	(0.37)
F	10	(0.4)

Unit in mm

LEAD STYLE

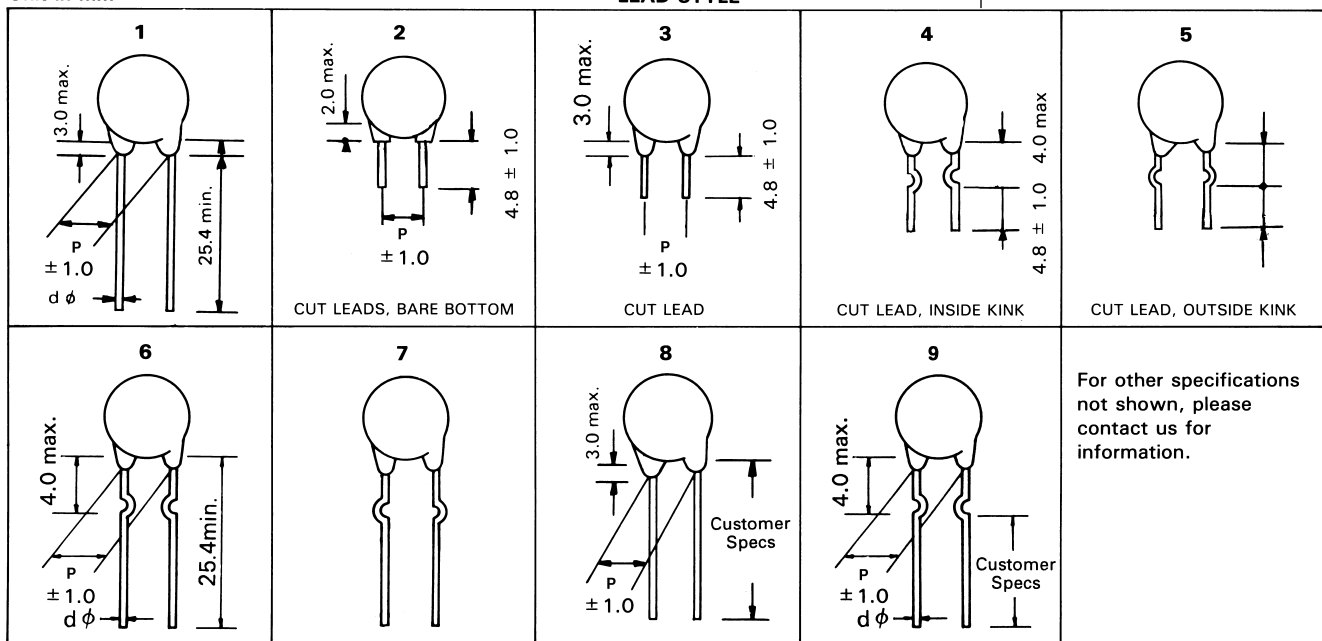

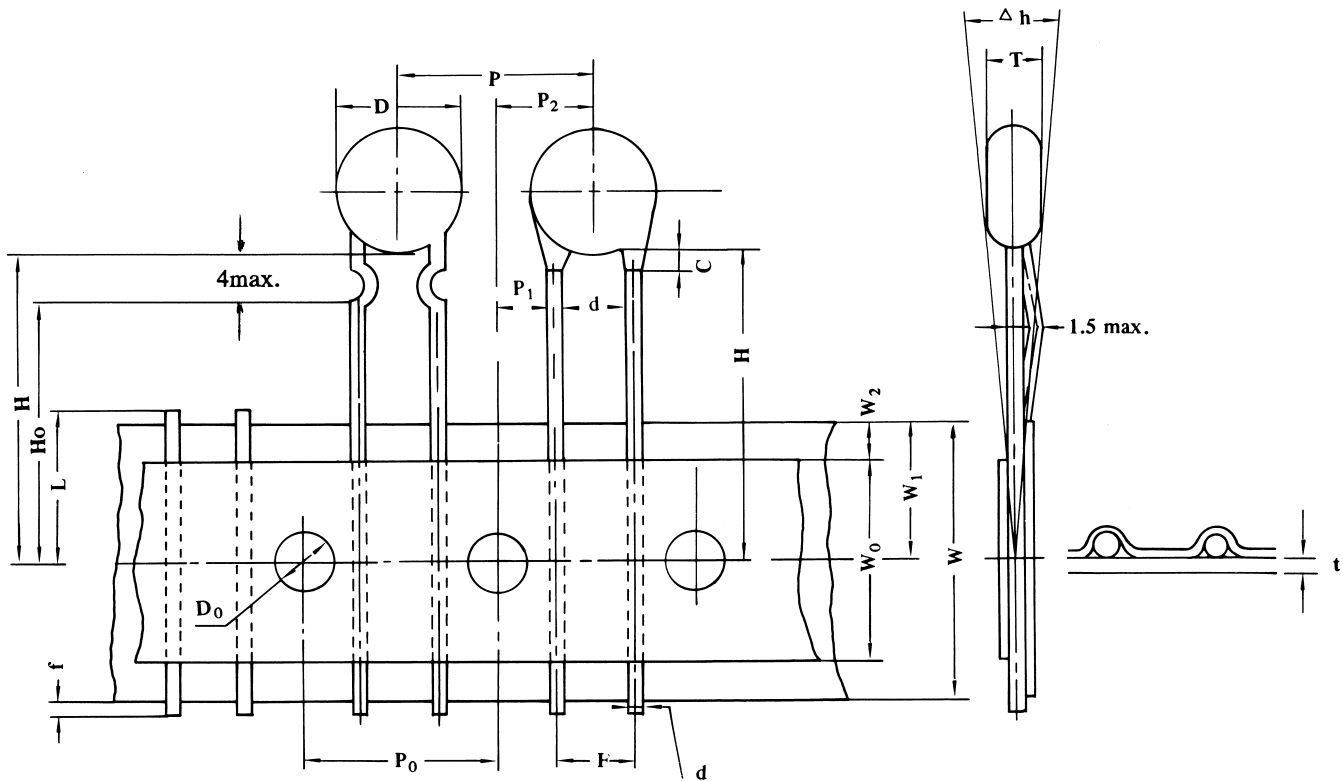

Item	Symbol	Specification	Remarks
Body diameter	D	10.0 maximum	
Body thickness	T	3.5 maximum	
Lead-wire diameter	d	0.50 ±0.05	
Pitch of component	P	12.7 ±1.0	
Feed hole pitch	P0	12.7 ±0.3	Cumulative pitch error: 1.0mm / 20 pitch.
Feed hole center to lead	P1	3.85 ±0.7	
Hole center to component center	P2	6.35 ±1.3	
Lead-to-lead distance	F	5.0 ±0.8	
Component alignment, F-R	Dh	0 ±2.0 mm	
Tape width	W	18.0 ±0.5	
Hold-down tape width	W0	11.0 maximum	
Hole position	W1	9.0 ±0.5	
Hold-down tape position	W2	3.0 maximum	
Height of component from tape center	H	20.0 ±1	
Component height	H1	32.25 maximum	
Lead-wire protrusion		2.0 maximum	
Feed hole diameter	Do	4.0 ±0.3	
Total tape thickness	t	0.7 ±0.2	Ground paper: 0.5mm + 0.1mm.
Length of snapped lead	L	11.0 maximum	
Coating rundown on leads	C	2.0 maximum	