

SPECIFICATIONS

Performance Characteristics	
Operating Temperature Range	-55°C ~ +125°C.
Voltage Range	6.3, 10, 16, 20, 25, 35, & 50VDC.
Surge Voltage	8, 13, 20, 26, 33, 46, & 65VDC.
Capacitance Range	0.1µF ~ 330µF.
Capacitance Tolerance (1KHz)	±10% & ±20%.
Maximum Dissipation Factor % (120Hz)	4 (CR 0.1µF ~ 1.5µF). 6 (CR 2.2µF ~ 6.8µF). 8 (CR 10µF ~ 68µF). 1 (CR 100µF ~ 330µF).
Environmental Classification	55/085/21 (IEC 68 - 2).
Reliability (85°C)	1% per 1000 hours with 0.1W/V series impedance, 60% confidence level.
Technical Data	All technical data relate to an ambient temperature of 20°C.

PART NUMBERING

Part Number Example: 511-016/100KSBF								
511	-	016	/	100	K	S	B	F
Type		Rated DC Voltage		Capacitance Code (µF)*	Tolerance Code	Wire Form	Package Code	RoHs Compliant
* Capacitance Code: First two digits represent significant figures, third digit represents multiplier (number of zeros).								
** Package Code: B = Bulk.								

CAPACITANCE RANGE (LETTER DENOTES CASE CODE)

Capacitance µF	WVDC						
	6.3	10	16	20	25	35	50
0.1						A	A
0.15						A	A
0.22						A	A
0.33						A	A
0.47						A	A
0.68						A	B
1.0				A	A	A	C
1.5			A	A	A	A	D
2.2		A	A	A	A	B	E
3.3	A	A	A	B	B	C	F
4.7	A	A	B	C	C	E	G
6.8	A	B	C	D	D	F	H
10	B	C	D	E	E	F	J
15	C	D	E	F	F	H	K
22	D	E	F	H	H	K	L
33	E	F	F	J	J	M	
47	F	G	J	K	M	N	
68	G	H	L	N	N		
100	H	K	N				
150	K	N					
220	M	P	R				
330	P	R					

Values outside this standard range may be available on request without appropriate release or qualification. TI reserves the right to supply capacitors to a tighter specification than that ordered.

Maximum ESRW @ 100kHz								
Capacitance μF	WVDC							
	6.3	10	16	20	25	35	50	
0.10						26.0	26.0	
0.15						21.0	21.0	
0.22						17.0	17.0	
0.33						15.0	15.0	
0.47						13.0	13.0	
0.68						10.0	10.0	
1.0				10.0	10.0	8.0	8.0	
1.5			10.0	9.0	8.0	6.0	5.0	
2.2		13.0	8.0	7.0	6.0	5.0	3.5	
3.3	13.0	10.0	6.0	5.5	5.0	4.0	3.0	
4.7	10.0	8.0	5.0	4.5	4.0	3.0	2.5	
6.8	8.0	6.0	4.0	3.6	3.1	2.5	2.0	
10	6.0	5.0	3.2	2.9	2.5	2.0	1.6	
15	5.0	3.7	2.5	2.3	2.0	1.6	1.2	
22	3.7	2.7	2.0	1.8	1.5	1.3	1.0	
33	3.0	2.1	1.6	1.4	1.2	1.0		
47	2.0	1.7	1.3	1.2	1.0	0.8		
68	1.8	1.3	1.0	0.9	0.8			
100	1.6	1.0	0.8	0.6				
150	0.9	0.8	0.6					
220	0.9	0.6	0.5					
330	0.7	0.5						

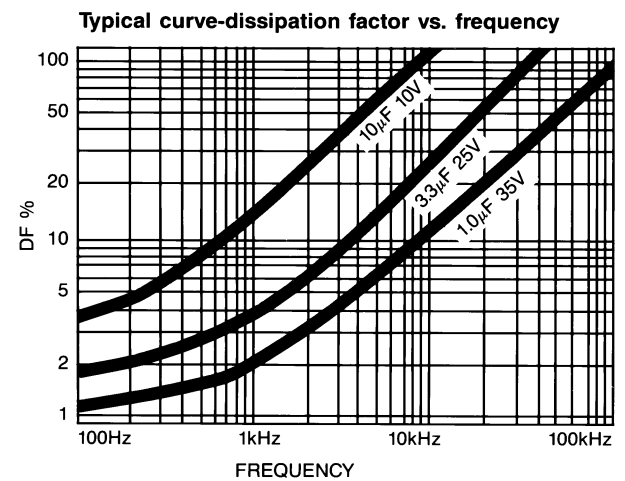
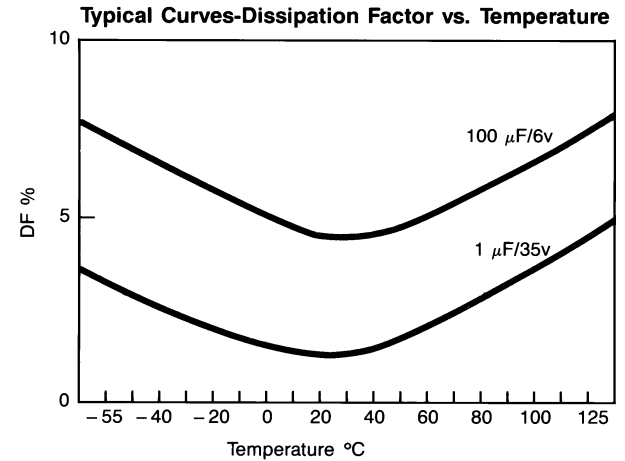

Maximum Leakage Current (μA)								
Capacitance μF	WVDC							
	6.3	10	16	20	25	35	50	
0.10						0.5	0.5	
0.15						0.5	0.5	
0.22						0.5	0.5	
0.33						0.5	0.5	
0.47						0.5	0.5	
0.68						0.5	0.5	
1.0				0.5	0.5	0.5	0.5	
1.5			0.5	0.5	0.5	0.5	0.6	
2.2		0.5	0.5	0.5	0.5	0.6	0.8	
3.3	0.5	0.5	0.5	0.5	0.6	0.9	1.3	
4.7	0.5	0.5	0.6	0.7	0.9	1.3	1.8	
6.8	0.5	0.5	0.8	1.0	1.3	1.9	2.7	
10	0.5	0.8	1.2	1.6	2.0	2.8	4.0	
15	0.7	1.2	1.9	2.4	3.0	4.2	6.0	
22	1.1	1.7	2.8	3.5	4.4	6.1	8.8	
33	1.6	2.6	4.2	5.2	6.6	9.2		
47	2.3	3.7	6.0	7.5	9.4	10.0		
68	3.4	5.4	8.7	10.8	13.6			
100	5.0	8.0	12.8	16.0				
150	7.5	12.0	19.2					
220	11.0	17.6	20.0					
330	16.6	20.0						

Case Dimensions (Inches (mm))			
Case	H	*H1	D
A	0.33 (8.5)	0.28 (7.0)	0.18 (4.5)
B	0.35 (9.0)	0.3 (6.5)	0.18 (4.5)
C	0.39 (10.0)	0.33 (8.5)	0.2 (5.0)
D	0.41 (10.5)	0.35 (9.0)	0.2 (5.0)
E	0.41 (10.5)	0.35 (9.0)	0.22 (5.5)
F	0.45 (11.5)	0.39 (10.0)	0.24 (6.0)
G	0.45 (11.5)	0.39 (10.0)	0.26 (6.5)
H	0.47 (12.0)	0.41 (10.5)	0.28 (7.0)
J	0.51 (13.0)		0.31 (8.0)
K	0.55 (14.0)		0.33 (8.5)
L	0.55 (14.0)		0.35 (9.0)
M	0.57 (14.5)		0.35 (9.0)
N	0.63 (16.0)		0.35 (9.0)
P	0.67 (17.0)		0.39 (10.0)
R	0.73 (18.5)		0.39 (10.0)

*H₁ refers to H dimension on S wire form (straight leads).

Wire Form and Outline

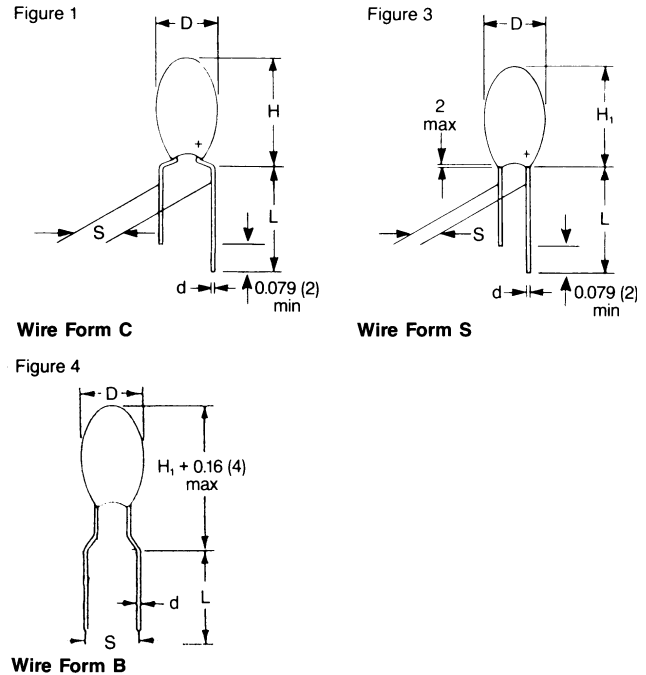

DIMENSIONS (INCHES (mm))

Wire Form	Figure	Case Size	L (see note 1)	Lead Spacing S	d	Packaging Suffixes Available*
C	Figure 1	A - R	0.630 ± 0.160 (16 ± 4)	0.200 ± 0.040 (5 ± 1)	0.020 ± 0.002 (0.5 ± 0.05)	CB Bulk CTR Tape/Reel CTA Tape/Ammo
H	Similar to Figure 1	A - R	0.630 ± 0.160 (16 ± 4)	0.250 ± 0.040 (6.35 ± 1)	0.020 ± 0.002 (0.5 ± 0.05)	H Bulk
S	Figure 3	A - H	0.630 ± 0.160 (16 ± 4)	0.100 ± 0.020 (2.5 ± 0.5)	0.020 ± 0.002 (0.5 ± 0.05)	SB Bulk STR Tape/Reel STA Tape/Ammo
B	Figure 4	A - H	0.630 ± 0.160 (16 ± 4)	0.200 ± 0.020 (5 ± 1)	0.020 ± 0.002 (0.5 ± 0.05)	BTR Tape/Reel BTA Tape/Ammo

Notes: (1) Lead lengths can be supplied to tolerances other than those above and should be specified in the ordering information.

DIMENSIONS (INCHES (mm))

Description	Code	Dimension
Feed hole pitch	P	0.5 ± 0.01 (12.7 ± 0.3).
Hole center to lead	P ₁	0.15 ± 0.03 (3.85 ± 0.7) to be measured at bottom of clinch.
		0.2 ± 0.04 (5.05 ± 1.0) for S wires.
Hole center to component center	P ₂	0.25 ± 0.02 (6.35 ± 0.4).
Change in pitch	Δp	±0.04 (±1.0).
Lead diameter	d	0.02 ± 0.003 (0.5 ± 0.05).
Lead spacing	S	See wireform table.
Component alignment	Δh	0 ± 0.08 (0 ± 2.0).
Feed hole diameter	D	0.15 ± 0.008 (4 ± 0.2).
Tape width	W	0.7 +0.04, -0.02 (18 +1.0, -0.5).
Hold down tape width	W ₁	0.24 (6) minimum.
Hold down tape position	W ₂	0.04 (1) maximum.
Lead wire clinch height	H	0.63 ± 0.02 (16 ± 0.5)
		0.75 ± 0.04 (19 ± 1.0) on request.
Hole position	H ₁	0.35 ± 0.02 (9.0 ± 0.5)
Base of component height	H ₂	0.7 (18) minimum.
Component height	H ₃	1.3 (32.25) maximum.
Length of snapped lead	L	0.43 (11.0) maximum.
Total tape thickness	T	0.03 ± 0.001 (0.7 ± 0.2).
		Carrying card 0.02 ± 0.005 (0.5 ± 0.1).

Reel Configuration and Dimensions inches (mm)

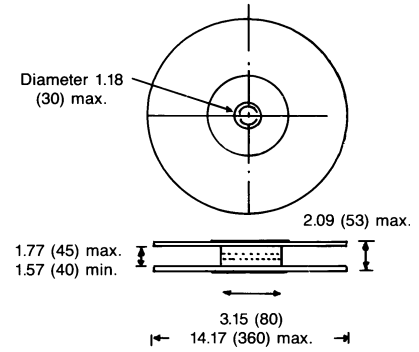

Manufactured from cardboard with plastic hub

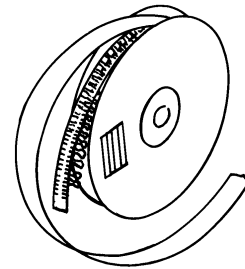

Holding tape outside

Positive terminal leading (negative terminal by special request)

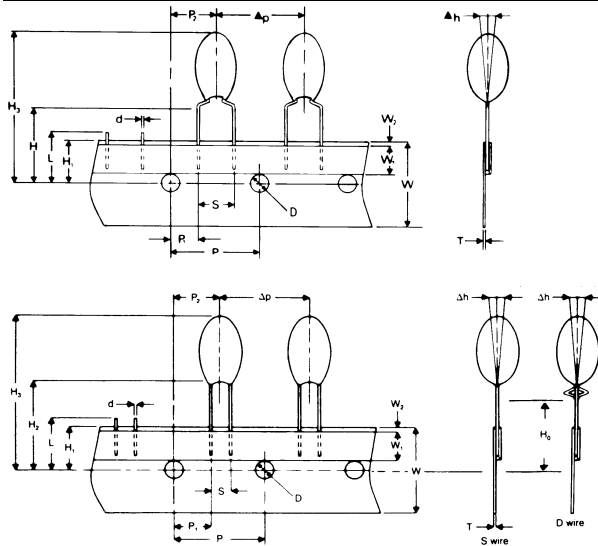

'B' wires for normal automatic insertion on 5mm pitch.

BTR suffix for reel.

BTA suffix for 'ammo' pack.

Available in case sizes A - H.

'C' wires for preforming.

CTR suffix for reel.

CTA suffix for 'ammo' pack.

Available in case sizes A - M.

'S' wire for special applications, automatic insertion on 2.5mm pitch.

STR suffix for reel.

STA suffix for 'ammo' pack.

Available in case sizes A - H.

PACKAGING QUANTITIES

FOR REELS

Case Code	No. of Pieces
A	1500
B, C, D	1250
E, F	1000
G, H, J	750
K, L, M	500

FOR 'AMMO' PACK

Case Code	No. of Pieces
A, B, C, D	3000
E, F, G	2500
H	2000

FOR BULK PRODUCTS

Case Code	No. of Pieces
A ~ H	1000