

FEATURES

- Unencapsulated, stacked, metallized polyester, polyethylene naphthalate (PEN) film construction, noninductive.
- Very small sizes: 1913, 2416, 2420, 2820, 3925, & 3931.
- Excellent moisture resistance.
- Reflow soldering Only.
- Tape/reel package.
- For ADSL only.

PART NUMBERING

Part Number Example: 932D-250/103JTR1913F								
932D	-	250	/	103	J	TR	1913	F
Type		Rated DC Voltage		Capacitance Code (pF)*	Tolerance Code	Package Code**	Reel Size	RoHs Compliant
* Capacitance Code: First two digits represent significant figures, third digit represents multiplier (number of zeros).								
** Package Code: TR = Tape & Reel.								

SPECIFICATIONS

Performance Characteristics	
Operating Temperature Range	-55°C ~ +85°C.
Voltage Range	250
Withstanding Voltage (between leads)	400VDC for 60 seconds applied through minimum 2KΩ resistor @ 250VDC.
Capacitance Range	0.001μF ~ 0.15μF.
Capacitance Tolerance	±5%.
Maximum Dissipation Factor % (20°C, 1KHz)	1.0.
Minimum Insulation Resistance (20°C) (after 1 minute minimum)	3000MΩ measured @ 250VDC.

DIMENSIONS IN mm:

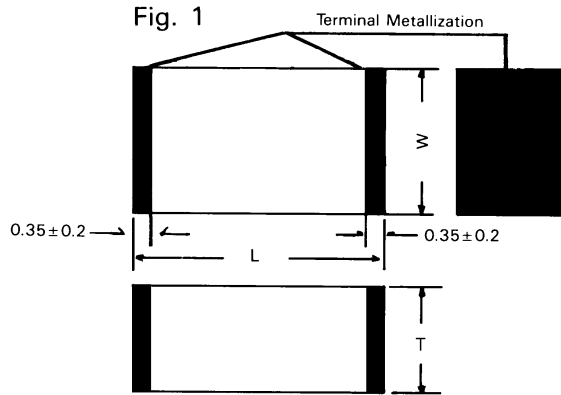

EIA SIZE CODE

EIA Size	Dimensions (mm)			Tolerance
	L	W	T	
1913	4.8±0.2	3.3±0.3	1.4	±0.2
			2.0	
			2.4	
			2.8	
2416	6.0±0.2	4.1±0.3	2.0	
			2.4	
			2.8	
			3.2	
2420	6.0±0.2	5.0±0.4	3.0	±0.3
			3.2	
			3.6	
			3.8	
			4.5	

STANDARD PRODUCTS TABLE OF T DIMENSION & QUANTITY PER REEL

Size (µF)	WVDC				
	250			Qty/Reel	400
	1913	2416	2420		1913
0.0010	1.4			3000	1.4
0.0012	1.4				1.4
0.0015	1.4				1.4
0.0018	1.4				1.4
0.0022	1.4				1.4
0.0027	1.4				1.4
0.0033	1.4				1.4
0.0039	1.4				1.4
0.0047	1.4				1.4
0.0056	1.4				2.0
0.0068	1.4				2.0
0.0082	1.4				2.4
0.010	1.4				2.8
0.012	1.4				
0.015	1.4				
0.018	2.0				
0.022	2.0				
0.027	2.4			2000	
0.033	2.8				
0.039		2.0		3000	
0.047		2.4			
0.056		2.8		2000	
0.068		3.2			
0.082			3.2	1500	
0.10			3.8		
0.12			4.5		

RECOMMENDED LAND PATTERN DIMENSIONS (mm)

Size	A	B	C
1913	2.6	6.6	3.0
2416	3.8	7.8	3.8
2420			4.6

