

FEATURES

- HIGH TEMPERATURE 125°C LONG LIFE
- 6.3V ~ 50V 2000hrs, 6.3D 1000hrs, 100V 1500hrs LIFE
- WIDE TEMPERATURE RANGE
- DESIGNED FOR AUTOMATIC MOUNTING
- SOLVENT RESISTANT

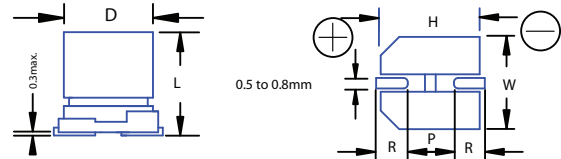

PART NUMBERING

Part Number Example: MXLX-025/330M6X6TR13FG

MXLX	-	025	/	330	M	6X6	TR	13	F	G
Type		Rated DC Voltage		Capacitance Code (μF)*	Tolerance Code	Size	Package Code**	Reel Size	RoHs Compliant	pb Free

* Capacitance Code: First two digits represent significant figure, third digit represents multiplier (number of zeros).
 ** Package Code: TR = Tape & Reel.

SPECIFICATIONS

Performance Characteristics								
Operating Temperature Range	-40°C ~ +125°C.							
Voltage Range	6.3VDC ~ 100VDC.							
Capacitance Range	1.0μF ~ 4700μF.							
Capacitance Tolerance	±20%.							
Maximum Dissipation Factor (20°C, 120Hz)	Rated Voltage (WVDC)	6.3	10	16	25	35	50	100
	DF%	30	24	20	16	14	14	10
Maximum Leakage Current (20°C) (after 2 minutes)	0.01CV or 3μA, whichever is greater.							
Load Life Test (105°C, 5000 hours for D ≥ 8.0mm) (105°C, 2000 hours for D < 8.0mm)	Capacitance Change	Within ±30% of initial measured value.						
	DF%	Less than 300% of specified value.						
	Leakage Current	Within maximum specified value.						

STANDARD PRODUCT TABLE (dØ X L(mm))

Cap. (μF)	WVDC						
	6.3	10	16	25	35	50	100
1.0						6.3 x 6	
2.2						6.3 x 6	
3.3						6.3 x 6	
4.7					6.3 x 6	6.3 x 6	
10					6.3 x 6	6.3 x 6	8 x 10.2
22					6.3 x 6	6.3 x 7.7	8 x 10.2
33						6.3 x 7.7	
33				6.3 x 6	6.3 x 7.7	8 x 10.2	10 x 10.2
47					6.3 x 7.7	8 x 10.2	
47		6.3 x 6	6.3 x 6	6.3 x 7.7	8 x 10.2	10 x 10.2	12.5 x 13.5
100				6.3 x 7.7	8 x 10.2	10 x 10.2	
100	6.3 x 6	6.3 x 7.7	8 x 10.2	8 x 10.2	10 x 10.2	12.5 x 13.5	16 x 16.5
220		8 x 10.2		8 x 10.2	10 x 10.2		
220	6.3 x 7.7		8 x 10.2	10 x 10.2	12.5 x 13.5	12.5 x 13.5	
330		6.3 x 7.7		10 x 10.2		12.5 x 13.5	
330	8 x 10.2	8 x 10.2	10 x 10.2	12.5 x 13.5	12.5 x 13.5	16 x 16.5	
470					12.5 x 13.5		
470	8 x 10.2	10 x 10.2	12.5 x 13.5	12.5 x 13.5	16 x 16.5	16 x 16.5	
680	10 x 10.2	12.5 x 13.5	12.5 x 13.5	12.5 x 13.5	16 x 16.5	16 x 16.5	
1000	12.5 x 13.5	12.5 x 13.5	12.5 x 13.5	16 x 16.5	16 x 16.5		
1500	12.5 x 13.5	12.5 x 13.5	16 x 16.5	16 x 16.5			
2200	12.5 x 13.5	16 x 16.5	16 x 16.5				
3300	16 x 16.5	16 x 16.5					
4700	16 x 16.5						

MAXIMUM RIPPLE (mA rms @ 100HZ & 125°C)

Cap. (µF)	WVDC						
	6.3	10	16	25	35	50	100
1.0						45	
2.2						45	
3.3						45	
4.7					60	45	
10					70	50	70
22					70	80	70
33						80	
33				70	110	140	115
47					110	140	
47		70	70	110	160	240	350
100				110	160	240	
100	70	110	160	160	220	490	500
220		110		160	220		
220	110		160	220	550	490	
330		160		220		490	
330	160	160	220	550	550	800	
470					550		
470	160	220	550	550	900	800	
680	220	550	550	550	900	800	
1000	550	550	550	900	900		
1500	550	550	900	900			
2200	550	900	900				
3300	900	900					
4700	900						

MAXIMUM ESR (Ω @ 100KHz & 20°C)

Cap. (µF)	WVDC						
	6.3	10	16	25	35	50	100
1.0						3.50	
2.2						3.50	
3.3						3.50	
4.7					2.00	3.50	
10					1.60	2.80	1.00
22					1.60	2.00	1.00
33						2.00	
33				1.60	0.90	0.70	0.80
47					0.90	0.70	
47		1.60	1.60	0.90	0.40	0.50	0.33
100				0.90	0.40	0.50	
100	1.60	0.90	0.40	0.40	0.30	0.23	0.24
220		0.90		0.40	0.30		
220	0.90		0.40	0.30	0.12	0.23	
330		0.40		0.30		0.23	
330	0.40	0.40	0.30	0.12	0.12	0.15	
470					0.12		
470	0.40	0.30	0.12	0.12	0.08	0.15	
680	0.30	0.12	0.12	0.12	0.08	0.15	
1000	0.12	0.12	0.12	0.08	0.08		
1500	0.12	0.12	0.08	0.08			
2200	0.12	0.08	0.08				
3300	0.08	0.08					
4700	0.08						

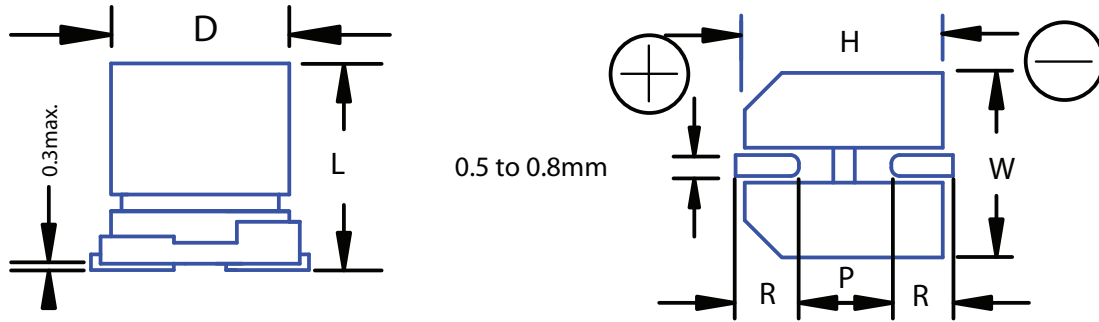

D +0.5 Max.	L	W ± 0.2	H ± 0.2	R	P ± 0.2
6.3	6.0 ± 0.3	6.6	6.6	2.35 ~ 2.75	2.2
6.3	7.7 ± 0.3	6.6	6.6	2.35 ~ 2.75	2.2
8.0	10.2 ± 0.3	8.3	8.3	2.7 ~ 3.1	3.2
10.0	10.2 ± 0.3	10.3	10.3	3.0 ~ 3.4	4.6
12.5	13.5 ± 0.5	12.8	12.8	4.25 ~ 4.65	4.6
16.0	16.5 +0.5	16.3	16.3	4.95 ~ 5.35	7.0