

METALLIZED POLYPROPYLENE (OPP), NON-INDUCTIVE, PLASTIC CASE, INTERFERENCE SUPPRESSORS CLASS X2

INTRODUCTION

THE TYPE MPXM CAPACITORS are constructed with metallized polypropylene film, dielectric, copper clad steel lead and encapsulated in plastic cases sealed with epoxy resin. They provide Interference Suppression with safety recognition of UL, VDE and others.

APPLICATION

THE TYPE MPXM CAPACITORS are ideal for using in Line-By-Pass, Antenna coupling, Across-The-Line and spark killer circuits and available for EMI filter and switching power supply applications.

FEATURES

- Non-inductive construction.
- Self-healing.
- Flame-retardant plastic case and epoxy resin (compliance with UL 94V-0).
- High moisture-resistance.
- Good solderability (plated with 100% Matte Sn).

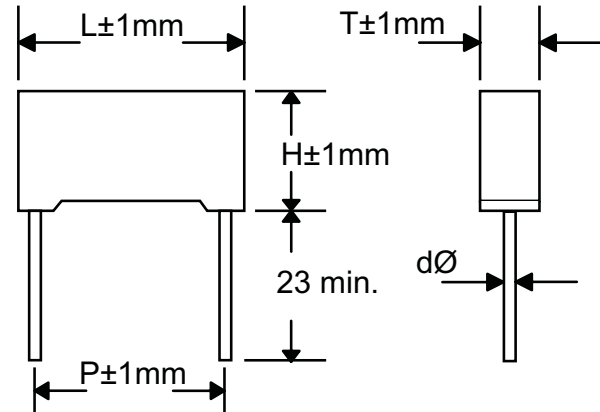

Country	Reference Standards	File No.
UL US & CANADA	UL 1414 60384-14	E164458
VDE (GERMANY)	VDE 0565 1	400141
SEV (SWITZERLAND)	NEK EN 132 400 (1994) iec 384 14 11 (1993)/a1 (1995)	08.0359
SEMKO (SWEDEN)	NEK EN 132 400 (1994) iec 384 14 11 (1993)/a1 (1995)	807300
DEMKO (DENMARK)	NEK EN 132 400 (1994) iec 384 14 11 (1993)/a1 (1995)	314644
NEMKO (NORWAY)	NEK EN 132 400 (1994) iec 384 14 11 (1993)/a1 (1995)	P08209
FIMKO (FINLAND)	NEK EN 132 400 (1994) iec 384 14 11 (1993)/a1 (1995)	24296

PART NUMBERING

Part Number Example: MPXM-275/104K10F							
MPXM	-	275	/	104	K	10	F
Type		Rated AC (RMS) Voltage		Capacitance Code (pF)*	Tolerance Code	Lead Spacing	RoHs Compliant

* Capacitance Code: First two digits represent significant figures, third digit represents multiplier (number of zeros).

SPECIFICATIONS

Performance Characteristics	
Operating Temperature Range	-40°C ~ +100°C
Voltage Range	275VAC (250VAC for UL & CSA).
Withstanding Voltage (between leads)	2000VDC for 1 second.
Capacitance Range	0.01µF ~ 1.0µF
Capacitance Tolerance	±10%.(K) , ±20%.(M)
Maximum Dissipation Factor	0.1% MAX @ 25 °C 1Khz
Minimum Insulation Resistance (23°C) (after 2 minute minimum)	IR ≥ 30000MΩ measured @ 100VDC ± 15VDC (C<0.33µF). IR ≥ 10000M ohm · µF measured @ 100VDC ± 15VDC (C > 0.33µF).

DIMENSIONS

Code	Size Cap. (µF)	L Maximum (mm)	H Maximum (mm)	T Maximum (mm)	P ± 1 (mm)	dØ (mm)
103	0.010	18.0	11.0	5.0	15	0.8
123	0.012	18.0	11.0	5.0	15	0.8
153	0.015	18.0	11.0	5.0	15	0.8
183	0.018	18.0	11.0	5.0	15	0.8
223	0.022	18.0	11.0	5.0	15	0.8
273	0.027	13.0	11.0	5.0	10	0.6
273	0.027	18.0	11.0	5.0	15	0.8
333	0.033	13.0	11.0	5.0	10	0.6
393	0.039	13.0	12.0	6.0	10	0.6
473	0.047	13.0	12.0	6.0	10	0.6
563	0.056	13.0	13.0	7.0	10	0.6
563	0.056	18.0	11.0	5.0	15	0.8
683	0.068	13.0	13.0	7.0	10	0.6
683	0.068	18.0	11.0	5.0	15	0.8
823	0.082	13.0	14.0	8.0	10	0.6
823	0.082	18.0	12.0	6.0	15	0.8
104	0.10	13.0	12.0	6.0	10	0.6
104	0.10	18.0	12.0	6.0	15	0.8
124	0.12	13.0	12.0	6.0	10	0.6
124	0.12	18.0	12.0	6.0	15	0.8
154	0.15	18.0	13.5	7.5	15	0.8
184	0.18	18.0	13.5	7.5	15	0.8
224	0.22	18.0	14.5	8.5	15	0.8
224	0.22	26.5	15.0	6.0	22.5	0.8
274	0.27	18.0	15.5	9.5	15	0.8
334	0.33	18.0	15.0	8.5	15.0	0.8
394	0.39	18.0	19.0	11.0	15.0	0.8
394	0.39	26.5	19.0	10.0	22.5	0.8
474	0.47	26.5	17.0	8.5	22.5	0.8
564	0.56	26.5	19.0	10.0	22.5	0.8
684	0.68	18.0	18.0	10.0	15.0	0.8
684	0.68	26.5	19.0	10.0	22.5	0.8
824	0.82	26.5	20.0	11.0	22.5	0.8
105	1.0	26.5	23.0	14.0	22.5	0.8
105	1.0	32.0	22.0	13.0	27.5	0.8