

POWER SUPPLY INPUT & OUTPUT FILTER CAPACITORS

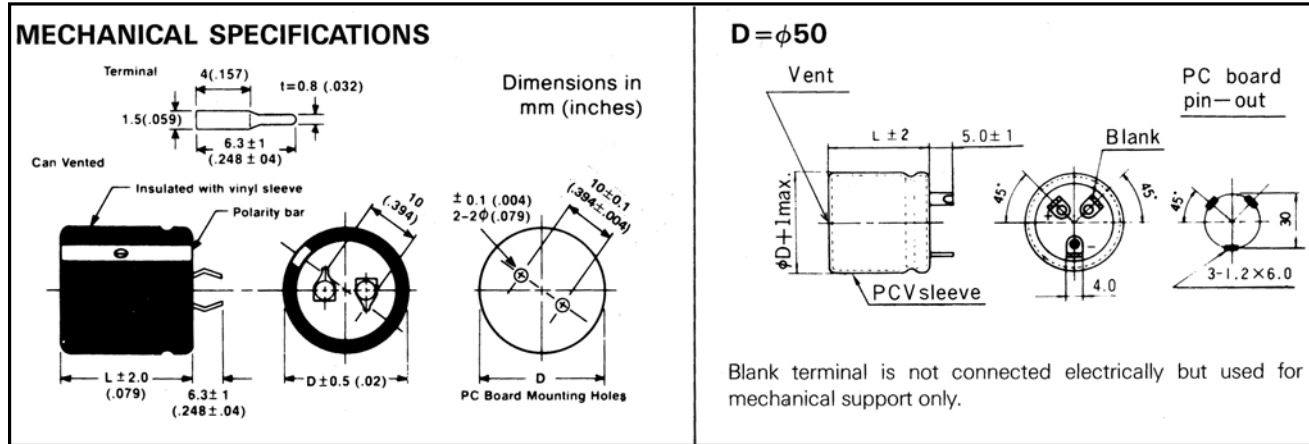

PART NUMBERING

Part Number Example: LG-050/103M30X50F							
LG	-	050	/	103	M	30X50	F
Type		Rated DC Voltage		Capacitance Code (μF)*	Tolerance Code	Size	RoHs Compliant

\* Capacitance Code: First two digits represent significant figures, third digit represents multiplier (number of zeros).

SPECIFICATIONS

Performance Characteristics									
	Type LG			Type LGE					
Operating Temperature Range	-40°C ~ +85°C @ 10VDC ~ 200VDC. -25°C ~ +85°C @ 250VDC ~ 450VDC.			-40°C ~ +105°C @ 10VDC ~ 100VDC. -25°C ~ +105°C @ 160VDC ~ 450VDC.					
Temperature Characteristics (120Hz)	Impedance Ratio								
	Rated Voltage (VVDC)			10 - 16	25	35	50 - 63	80 - 100	160 - 450
	Z (-25°C) / Z (+20°C)			4	3	3	2	2	4
Z (-40°C) / Z (+20°C)			15	10	8	6	5		
Capacitance Tolerance (20°C, 120Hz)	±20%. (-10%, +30% (Q) is available at request).			±20%.					
Maximum Dissipation Factor % (20°C, 120Hz)	Dissipation factor shall not exceed the values given in the table of standard rating.								
Maximum Leakage Current (20°C) (after 5 minutes)	0.02CV or 3mA, whichever is smaller. (I = Maximum leakage current (μA), C = Nominal capacitance (μF), V = Rated working voltage).								
Applicable Standards	Satisfies characteristic of JIS C5141.								
Load Life Test	The following specifications shall be satisfied when the capacitors are restored to 20°C after the rated working voltage applied for 1000 hours @ 85°C.								
	Capacitance Change			Within ±20% of initial value.					
	Dissipation Factor			150% of initial specified value.					
Leakage Current			Initial specified value.						
Shelf Life	The following specifications shall be satisfied when the capacitors are restored to 20°C after exposing them @ 85°C for 500 hours without voltage applied. The rated voltage shall be applied to the capacitors for a minimum of 30 minutes, at least 24 hours and not more than 48 hours before the measurements.								
	Capacitance Change			Within ±20% of initial value.					
	Dissipation Factor			150% of initial specified value.					
Leakage Current			Initial specified value.						

WVDC	Rated Capacitance (μF)	Dimensions	Maximum DCL (mA)	Maximum DF (tan δ)	Maximum ESR (Ω @ 20°C)		Maximum RMS Ripple Current (mA) @ 120Hz, 85°C
		D x L (mm)			@ 120Hz	@ 10KHz ~ 30KHz	
10	10000	22 x 40	2.00	0.40	0.053	0.043	2400
		30 x 25					
	15000	22 x 40	3.00	0.40	0.040	0.036	2500
		30 x 30					
	22000	25 x 50	3.00	0.40	0.032	0.028	3800
35 x 30							
33000	30 x 50	3.00	0.50	0.020	0.018	4500	
47000	35 x 50	3.00	0.50	0.015	0.013	5000	
16	4700	25 x 25	1.50	0.25	0.079	0.060	2450
		22 x 30					
	6800	22 x 30	2.18	0.25	0.055	0.040	3100
		25 x 25					
	10000	22 x 40	3.00	0.35	0.052	0.035	3850
		30 x 25					
	15000	22 x 50	3.00	0.35	0.035	0.025	4600
35 x 30							
22000	30 x 50	3.00	0.40	0.025	0.020	4700	
	35 x 35						
33000	35 x 50	3.00	0.45	0.020	0.017	4800	
3300	25 x 25	1.65	0.20	0.060	0.065	2400	
25	4700	22 x 30	2.35	0.25	0.079	0.050	2900
		25 x 25					
	6800	22 x 40	3.00	0.25	0.055	0.040	3500
		30 x 25					
	10000	22 x 50	3.00	0.35	0.052	0.035	4200
		30 x 30					
	15000	25 x 50	3.00	0.35	0.035	0.025	4800
35 x 30							
22000	30 x 50	3.00	0.40	0.025	0.022	4900	
	40 x 40						
2200	25 x 25	1.54	0.20	0.130	0.110	2400	
35	3300	22 x 30	2.31	0.20	0.090	0.060	3000
		25 x 25					
	4700	22 x 40	3.00	0.25	0.050	0.060	3600
		30 x 25					
	6800	22 x 40	3.00	0.25	0.055	0.040	4000
		30 x 30					
	10000	25 x 50	3.00	0.30	0.045	0.035	4600
35 x 30							
15000	30 x 50	3.00	0.35	0.035	0.025	4700	
	35 x 40						
22000	35 x 50	3.00	0.40	0.035	0.025	4800	
	40 x 40						
50	1000	25 x 25	1.00	0.18	0.260	0.140	1400
		22 x 30					
	2200	22 x 30	2.20	0.20	0.130	0.100	2500
		25 x 25					
	3300	22 x 40	3.00	0.20	0.090	0.055	3100
		30 x 25					
	4700	22 x 50	3.00	0.25	0.078	0.050	3700
		35 x 30					
	6800	25 x 50	3.00	0.25	0.055	0.040	4200
35 x 30							
10000	30 x 50	3.00	0.35	0.050	0.038	4300	
	35 x 35						
15000	35 x 50	3.00	0.35	0.033	0.030	4500	
	40 x 40						
22000	50 x 40	3.00	0.45	0.032	0.028	4700	

WVDC	Rated Capacitance (μF)	Dimensions	Maximum DCL (mA)	Maximum DF (tan δ)	Maximum ESR (Ω @ 20°C)		Maximum RMS Ripple Current (mA) @ 120Hz, 85°C
		D x L (mm)			@ 120Hz	@ 10KHz ~ 30KHz	
65	1000	22 x 25	1.26	0.18	0.265	0.140	1900
		25 x 25					
	2200	22 x 40	2.77	0.20	0.100	0.100	2900
		30 x 25					
	3300	22 x 50	3.00	0.20	0.090	0.050	3300
		30 x 30					
	4700	25 x 50	3.00	0.25	0.075	0.050	3800
		35 x 30					
6800	30 x 50	3.00	0.25	0.050	0.048	4300	
	35 x 35						
10000	35 x 50	3.00	0.35	0.048	0.046	4400	
	40 x 40						
15000	50 x 40	3.00	0.45	0.042	0.040	4500	
80	1000	22 x 30	1.60	0.15	0.220	0.130	2000
		25 x 25					
	2200	22 x 40	3.00	0.20	0.130	0.090	3000
		35 x 30					
	3300	25 x 50	3.00	0.20	0.090	0.050	3500
		35 x 30					
	4700	30 x 50	3.00	0.25	0.075	0.050	3900
		35 x 35					
6800	35 x 50	3.00	0.25	0.050	0.048	4500	
	40 x 40						
10000	50 x 40	3.00	0.35	0.048	0.046	4600	
100	1000	22 x 40	2.00	0.15	0.220	0.140	2000
		30 x 25					
	2200	25 x 50	3.00	0.20	0.130	0.090	2800
		35 x 50					
	3300	30 x 50	3.00	0.20	0.100	0.080	3500
		35 x 35					
4700	35 x 50	3.00	0.20	0.080	0.060	4000	
	40 x 40						
6800	50 x 40	3.00	0.25	0.070	0.050	4600	
160	330	22 x 30	1.06	0.10	0.045	0.160	1300
		25 x 25					
	470	22 x 40	1.50	0.10	0.310	0.150	1600
		30 x 25					
	680	22 x 50	2.18	0.10	0.217	0.140	1800
		35 x 25					
	820	25 x 50	2.62	0.10	0.180	0.130	2000
35 x 50							
1000	30 x 40	3.00	0.10	0.135	0.120	2500	
	35 x 35						
180	220	22 x 30	0.80	0.10	0.670	0.200	1100
		25 x 25					
	330	22 x 40	1.19	0.10	0.440	0.180	1500
		30 x 25					
	470	22 x 50	1.69	0.10	0.314	0.150	1800
		30 x 30					
	680	25 x 50	2.45	0.10	0.220	0.140	2100
35 x 30							
820	30 x 40	2.95	0.10	0.180	0.130	2200	
	35 x 30						
1000	30 x 50	3.00	0.10	0.160	0.120	2500	
	35 x 35						

WVDC	Rated Capacitance (μF)	Dimensions	Maximum DCL (mA)	Maximum DF (tan δ)	Maximum ESR (Ω @ 20°C)	Maximum RMS Ripple Current (mA) @ 120Hz, 85°C
		D x L (mm)			@ 120Hz	
200	150	22 x 30	0.60	0.10	0.983	1250
		25 x 25				
	220	22 x 30	0.88	0.10	0.905	1150
		25 x 25				
		25 x 30	0.88	0.10	0.670	1650
		30 x 25				
	270	25 x 40	1.08	0.10	0.540	1950
		30 x 30				
	330	22 x 40	1.32	0.10	0.600	1400
		30 x 25				
		30 x 30	1.32	0.10	0.450	2200
	390	25 x 50	1.56	0.10	0.380	2500
		35 x 30				
	470	22 x 50	1.88	0.10	0.320	1900
		30 x 30				
		30 x 40	1.88	0.10	0.320	2700
	560	25 x 50	2.24	0.10	0.350	1800
		30 x 30				
30 x 50		2.24	0.10	0.260	3100	
35 x 40						
680	25 x 50	2.72	0.10	0.290	2150	
	35 x 30					
	35 x 40	2.72	0.10	0.210	3600	
820	30 x 50	3.00	0.10	0.250	2400	
	35 x 35					
	35 x 50	3.00	0.10	0.180	4200	
1000	35 x 40	3.00	0.10	0.190	2800	
250	100	22 x 30	0.50	0.15	0.150	1000
		25 x 25				
	150	22 x 30	0.75	0.15	0.133	900
		25 x 25				
		25 x 30	0.75	0.15	0.98	1350
		30 x 25				
	180	25 x 30	0.90	0.15	0.81	1500
	220	22 x 40	1.10	0.15	0.90	1150
		30 x 25				
		25 x 40	1.10	0.15	0.67	1750
	30 x 30					
	270	30 x 30	1.35	0.15	0.54	2000
	330	22 x 50	1.65	0.15	0.60	1400
		30 x 30				
		25 x 50	1.65	0.15	0.44	2300
		35 x 30				
	390	25 x 50	1.95	0.15	0.51	1500
		35 x 30	1.95	0.15	0.37	2600
470	25 x 50	2.35	0.15	0.42	1700	
	35 x 30					
	30 x 50	2.35	0.15	0.31	3000	
	35 x 40					
560	30 x 50	2.80	0.15	0.35	1800	
680	30 x 50	3.00	0.15	0.29	2100	
	35 x 50	3.00	0.15	0.21	3800	
820	35 x 50	3.00	0.15	0.20	2500	
1000	35 x 50	3.00	0.15	0.18	2800	

WVDC	Rated Capacitance (μF)	Dimensions	Maximum DCL (mA)	Maximum DF (tan δ)	Maximum ESR (Ω @ 20°C)	Maximum RMS Ripple Current (mA) @ 120Hz, 85°C
		D x L (mm)			@ 120Hz	
315	150	22 x 30	0.63	0.15	1.99	900
		25 x 25				
	220	22 x 50	1.38	0.15	0.90	1300
		30 x 30				
330	25 x 50	2.08	0.15	0.60	1800	
	35 x 30					
	470	30 x 50	2.96	0.15	0.42	2400
350	82	22 x 30	0.57	0.15	2.42	700
		25 x 25				
	100	22 x 30	0.70	0.15	1.99	850
		25 x 25				
	220	22 x 50	1.54	0.15	0.90	1400
		30 x 30				
330	30 x 40	2.31	0.15	0.60	1800	
	35 x 30					
400	82	22 x 30	0.66	0.15	2.42	700
		25 x 25				
	100	22 x 40	0.80	0.15	1.99	900
		30 x 25				
	150	25 x 40	1.20	0.15	1.32	1100
		30 x 30				
220	25 x 50	1.76	0.15	0.90	1500	
	35 x 30					
330	30 x 50	2.64	0.15	0.60	1900	
	35 x 35					
450	82	22 x 40	0.74	0.15	2.42	700
	100	22 x 40	0.90	0.15	1.99	900
	150	25 x 50	1.35	0.15	1.32	1100
	220	30 x 50	1.98	0.15	0.90	1600
	330	35 x 50	2.97	0.15	0.60	2000