

CAP-XX APPLICATION NOTE No. 1002

Start-Up Current-Limiters for Supercapacitors in PDAs, PC Card and USB Modems and Other Portable Devices

Revision 3.0, Aug 2008

Outline

Supercapacitors with low ESR (Equivalent Series Resistance) and high capacitance are ideal components for use in pulsed-power applications, such as GSM and GPRS transmitters, in which the load draws large pulses of current. When connected across the supply, they provide much of the energy needed by each load pulse, reducing voltage ripple and instantaneous supply current. However, they draw a high charging current when the device is turned on. This can cause a battery to shut down, or the supply voltage in a host device to drop because of overloading. This application note describes a high performance current-limit circuit as a CAP-XX solution and a simpler solution based on using a current limit IC. One such IC from AnalogicTech is evaluated which operates on power-up and during operation, allowing the supercapacitor to charge without overloading the supply.

The CAP-XX Solution

A solution to the start-up current problem is to limit the current to a safe, known value until the supercapacitor is charged. The CAP-XX solution operates with a supply voltage between 3V and 5.5V and employs a voltage reference, a sense resistor, an op-amp and a MOSFET. This solution has a settling time of 10µsec and typical impedance of 40mΩ comprising of a current sense resistor = 22mΩ + FET $R_{DS(ON)}$ of 18mΩ. Performance can be improved by using a FET with a lower $R_{DS(ON)}$. Table 1 lists some other possible FETs.

Circuit Operation

Introduction

The CAP-XX solution in figure 1 measures and controls the current delivered by the supply using an operational amplifier and a P type MOSFET in its linear region.

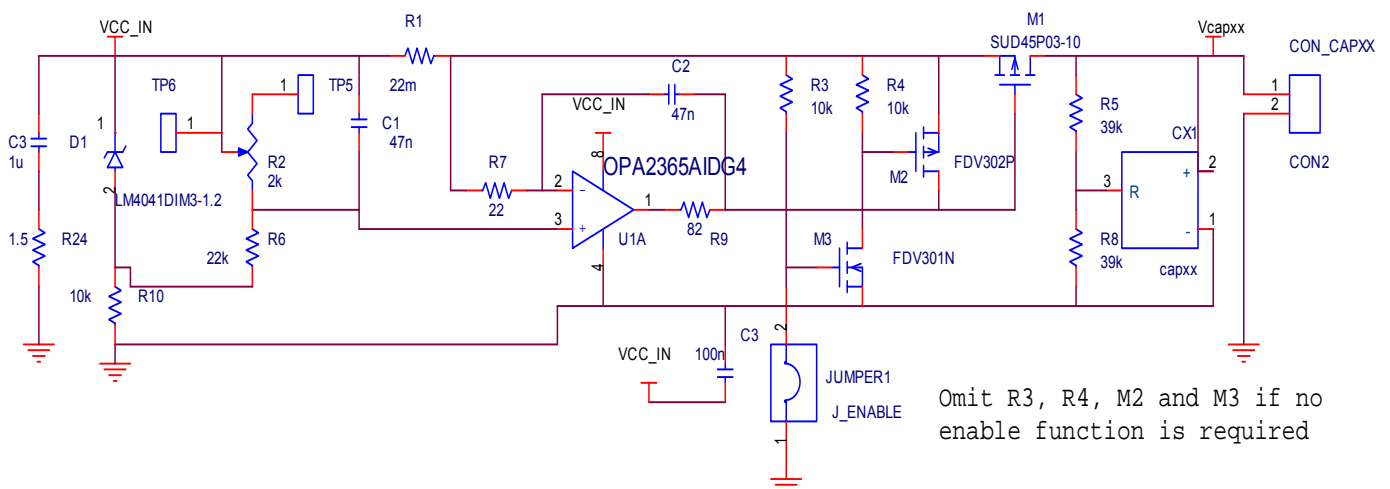

Figure 1: Current-Limiter using an Operational Amplifier and a MOSFET in Constant-Current Feedback
Design with optional ENABLE and POWER GOOD circuits

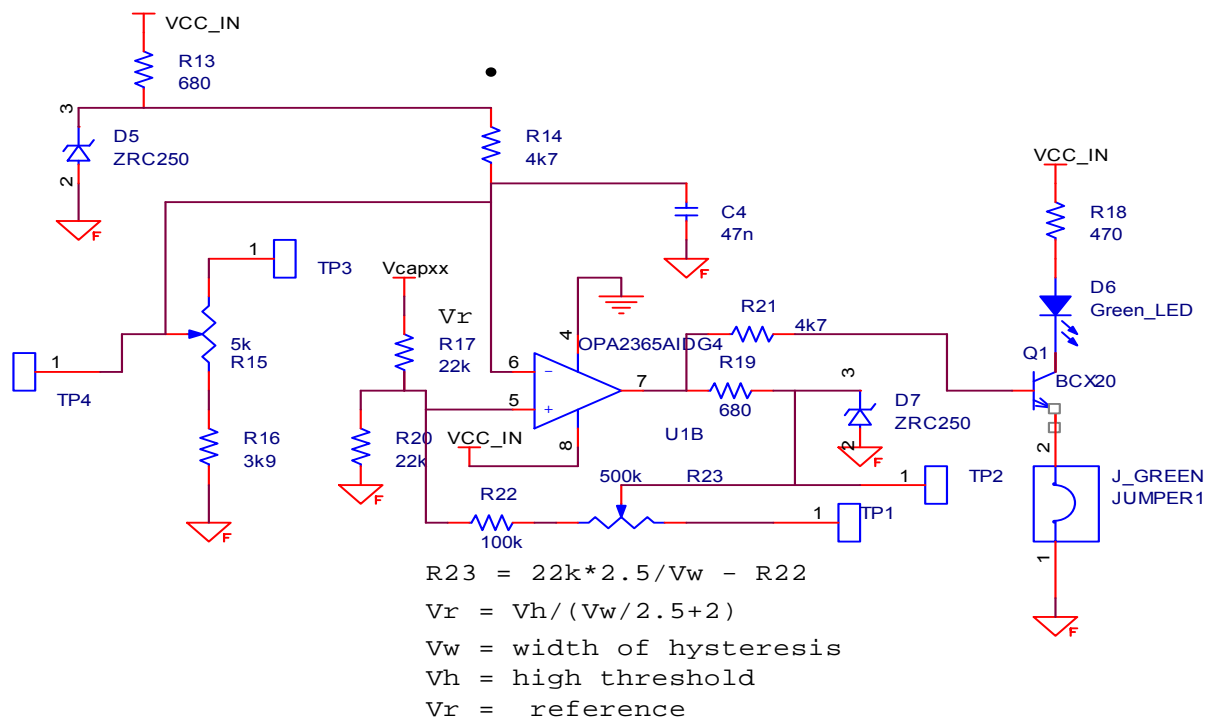

Figure 2: Power Good Circuit. The component values in the circuit were selected for operation at 3V to 5.5V. If enabled, it will limit the current drawn from the supply at any time that the load draws a high current. With the operational amplifiers used, the set

This circuit is ideal for USB, PC Card and CF Card applications, not only to limit inrush current, but also when the designer wishes to make sure that the design complies with the maximum current specification, rather than relying on the ratio of source impedance of the host device and the ESR of the supercapacitor to limit the current. Relying on the source impedance of the host is particularly problematic, as there is a wide variation in this value between products. The designer need only ensure that the circuit with the current-limiter operating will still provide adequate current for the load. In this regard, the designer is referred to cap-XX Application Note 1003 and the calculation/simulation aids available on the cap-XX web site: [SupercapPulseSimulatorFixedCurrent.xls](#) and [SupercapPulseSimulatorFixedPower.xls](#).

The portion of Figure 1 enclosed in the dotted rectangle is an optional “enable” circuit. If an “enable/disable” function is not required, these components may be omitted.

Also shown (Figure 2) is a circuit that generates a POWER GOOD output when the voltage on the supercapacitor has reached a desired value. This circuit is optional and may be used with any of the current-limiter circuits presented.

Feedback Control Design

Figure 1 is a current-limiter circuit that monitors the actual current and uses feedback to control current flow through the MOSFET. The supercapacitor charged by the circuit is represented by CX1. It has two cells in series, and its associated balancing resistors are R_5 and R_8 . The limiting current value is independent of the supercapacitor value.

The circuit in Figure 2 detects when the voltage on the supercapacitor has reached a predetermined value and outputs a “POWER GOOD” (active high) signal that may be used to

signal to other circuits that the supercapacitor is fully charged. The circuits 1 and 2 are designed to operate from a supply range of 3V to 5.5V, which is the maximum rated voltage of the two-cell supercapacitor.

The circuit in Fig 1 monitors the current by comparing the voltage drop across a sense resistor (R_1) with a reference voltage derived from a voltage reference IC (D1). If the voltage across the sense resistor exceeds the reference value, the current is too high and the operational amplifier output begins to turn off the MOSFET, M_1 . When the supercapacitor is charged, the current drops and M_1 is turned on fully, again.

If the optional “ENABLE” circuit is included, then a logic 0 signal (0V) applied to the input is required to enable the current-limiter circuit to operate; if the input is high or left floating, then M_1 is held off by M_2 , with the result that there is no current flow to the load.

The voltage reference circuits D_1 , D_5 and D_7 were selected for their accuracy and low power consumption. It may be possible to replace these with cheaper zener diodes, if required, provided the parts used have good tolerances (preferably 1%) across the temperature range of operation, otherwise the limit current and the voltage at which the POWER GOOD signal is generated might be incorrect. Zener diodes will typically require higher bias currents, resulting in increased power consumption by the circuit.

The operational amplifier used, OPA2365AIDG4 has a maximum input offset voltage of $100\mu\text{V}$ and a typical value of $20\mu\text{V}$. Since this parameter affects the accuracy of the current limit and the POWER GOOD signal, amplifiers with higher offset voltages should not be used. To a first order approximation, the current limit accuracy =

$$\frac{\text{Offset_voltage}}{V_{D1} \times \frac{R_2}{(R_2 + R_6)}}$$

This operational amplifier also has a fast slew rate of $25\text{V}/\mu\text{sec}$ thus ensuring fast current control. Note also that if the POWER GOOD circuit is used separately, its operational amplifier’s power supply should be bypassed with a 100nF capacitor.

The POWER GOOD circuit compares a proportion of the voltage across the supercapacitor with a reference voltage. When the supercapacitor voltage exceeds a predetermined value, the POWER GOOD output goes high. Some hysteresis is introduced via the feedback resistor, R_{22} .

Figure 3 shows the supply current (limited to 500mA) and voltage (set at 3.3V) as well as the supercapacitor current and voltage.

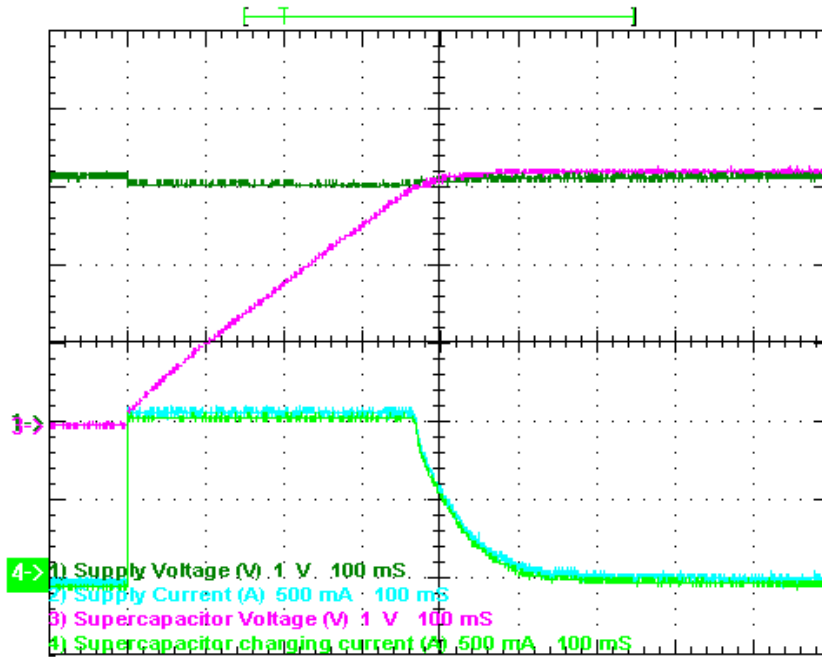

Figure 3: Charging a CAP-XX supercapacitor (0.12F and 50mΩ) using 3.3V supply and a current limit of 1A (CAP-XX solution)

Relationship between maximum current and component values: The current limit in Figure 1 may be selected by appropriate choice of the resistors in the voltage divider across the reference voltage, i.e., R_2 and R_6 . First, the shunt voltage when the current is at its limiting value is given by

$$v_{R1} = i_{Lim} \cdot R_1 \quad (1)$$

The voltage at the non-inverting input of the operational amplifier at the moment the current-limiting begins will be

$$v_+ = \frac{R_2}{R_2 + R_6} V_{D1} \quad (2)$$

Where, V_{D1} is the voltage across D_1 . Substituting v_+ as v_{R1} in equation (2), we have the following result for the limiting current as a function of the resistor values:

$$i_{Lim} = \frac{R_2}{R_1(R_2 + R_6)} V_{D1} \quad (3)$$

Alternatively, we may express the value of R_2 in terms of the desired maximum current and the other values, as follows:

$$R_2 = \frac{i_{Lim} R_1 R_6}{V_{D1} - i_{Lim} R_1} \quad (4)$$

Example: Using the values given in Figure 1, which include a 1.225V reference for D_1 , and if the desired maximum current is 500mA, Equation 4 gives 203Ω for the value of R_2 .

Relationship between POWER GOOD threshold voltage on the supercapacitor and the component values: Refer to Figure2. If the output of the operational amplifier is low because the voltage on the supercapacitor is low, then the voltage at the non-inverting input may be shown to be the following:

$$v_{+(PGLow)} = \frac{V_{S(PGLow)}}{R_{17}(1/R_{20} + 1/R_{22}) + 1} \quad (5)$$

Where, $v_{S(PGLow)}$ is the voltage on the supercapacitor. Likewise, if the output of the operational amplifier is high because the voltage on the supercapacitor is above the reference value, then the voltage at the non-inverting input may be shown to be the following:

$$v_{+(PGHigh)} = \frac{v_{S(PGHigh)}R_{20}R_{22} + V_{D7}R_{17}R_{20}}{R_{17}R_{22} + R_{20}R_{22} + R_{17}R_{20}} \quad (6)$$

where V_{D7} is the voltage on the reference device connected to R_{22} . However, the switching points in the POWER GOOD signal occur when each of $v_{+(PGLow)}$ and $v_{+(PGHigh)}$ is equal to the voltage at the inverting input. The reference voltage at the inverting input to the amplifier is given by the following:

$$v_- = \frac{R_{16}}{R_{14} + R_{16}} V_{D5} \quad (7)$$

where V_{D5} is the voltage at the reference IC/diode, D_5 . The supercapacitor voltage at which the POWER GOOD signal changes from low to high as the supercapacitor charges is when $v_{+(PGLow)}$ (Equation 5) is equal to v_- (Equation 7), as follows:

$$v_{s(PGLow)} = \frac{V_{D5}R_{16}[R_{17}(1/R_{20} + 1/R_{22}) + 1]}{R_{14} + R_{16}} \quad (8)$$

Similarly, the supercapacitor voltage at which the POWER GOOD signal changes from high to low as the supercapacitor discharges is found by equating $v_{+(PGHigh)}$ (Equation 6) and v_- (Equation 7), as follows:

$$v_{s(PGHigh)} = \frac{V_{D5}R_{16}(R_{17}R_{22} + R_{20}R_{22} + R_{17}R_{20})}{R_{20}R_{22}(R_{14} + R_{16})} - V_{D7} \frac{R_{17}}{R_{22}} \quad (9)$$

NOTE: As discussed above, "PGLow" and "PGHigh" refer to the state of the POWER GOOD signal at the time the voltage on the supercapacitor is considered. The effect of hysteresis is that the voltage $v_{S(PGLow)}$ is higher than the voltage $v_{S(PGHigh)}$.

Example: Using the component values given in Figure 1, which include 2.5V reference devices as D_5 and D_7 , the POWER GOOD circuit has a nominal switching voltage of 3.0V (from Equation 7). When the supercapacitor is charging, the voltage at which POWER GOOD goes from low to high is $v_{S(PGLow)} = 3.07V$ (from Equation 8). When the supercapacitor is discharging, the voltage at which POWER GOOD goes from high to low is $v_{S(PGHigh)} = 2.93V$ (from Equation 9).

Transient Behaviour while charging a supercapacitor

Figure 4 and 5 below show the transient behaviour of the CAP-XX solution to charge a supercapacitor using 1A current limit with 3.3V and 500mA current limit at 5.5V. To test the circuit, the CAP-XX supercapacitor was completely discharged and then connected to the output of the current limiting circuit.

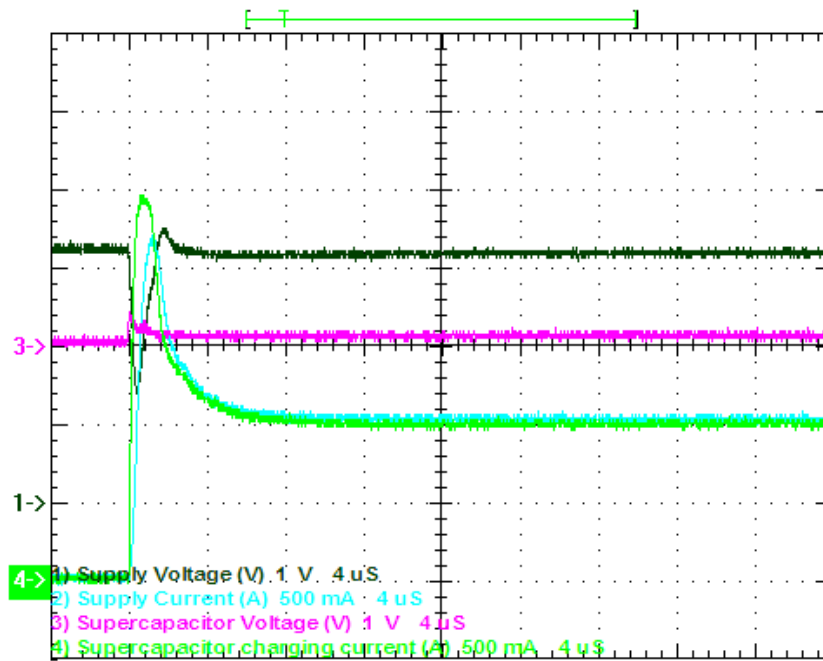

Figure 4: Charging a supercapacitor (0.12F and 50mΩ, initially at 0V) using a 3.3V supply and the circuit set to 1A current limit (CAP-XX solution)

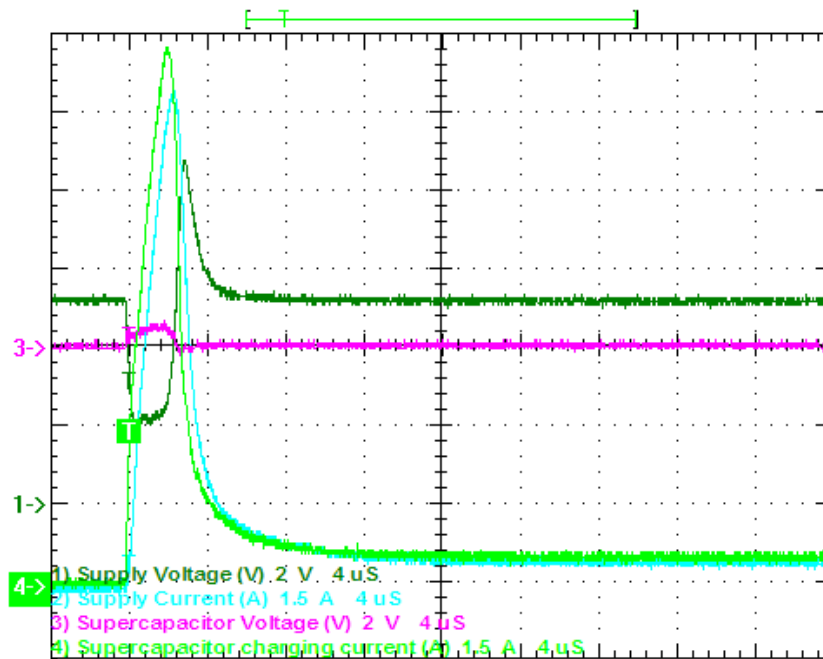

Figure 5: Charging a supercapacitor (0.12F and 50mΩ, initially at 0V) using a 5.5V Supply and the circuit set to 500mA current limit (CAP-XX solution)

A host device (for example, USB) with sufficient decoupling on its supply could deliver the 10 Amps transient current for 8 μsec without resetting itself.

Performance with Class 10 GPRS load

The CAP-XX solution can also effectively limit the current while a class 10 GPRS load is applied to the supercapacitor. The GPRS pulse is a 4.6msec long pulse with 25% duty-cycle at 1.8Amps. The following graphs show the response of the supply current and voltage with the GPRS load on the supercapacitor.

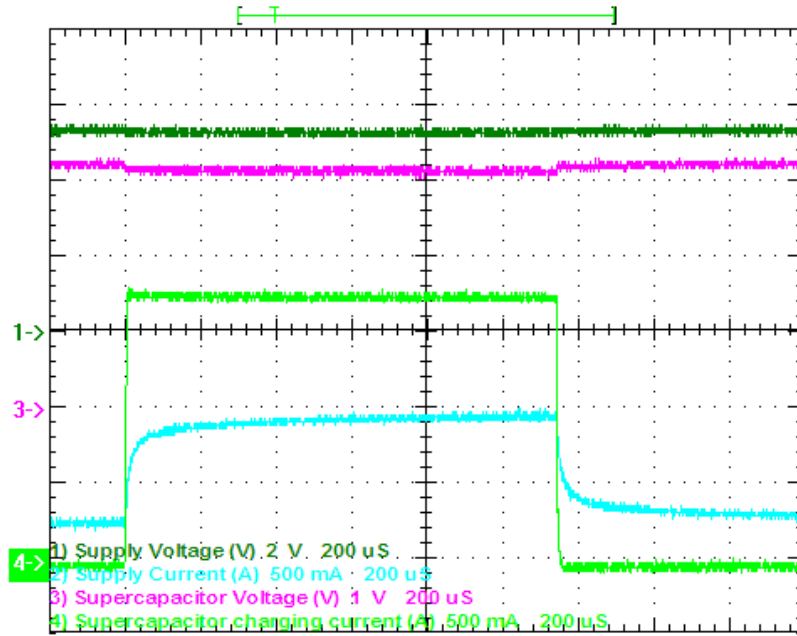

Figure 6: Load of a Class 10 GPRS pulse (1.8A) and a supercapacitor (0.12F and 50mΩ) with the supply at 3.3V and current limit set to 1A (CAP-XX solution)

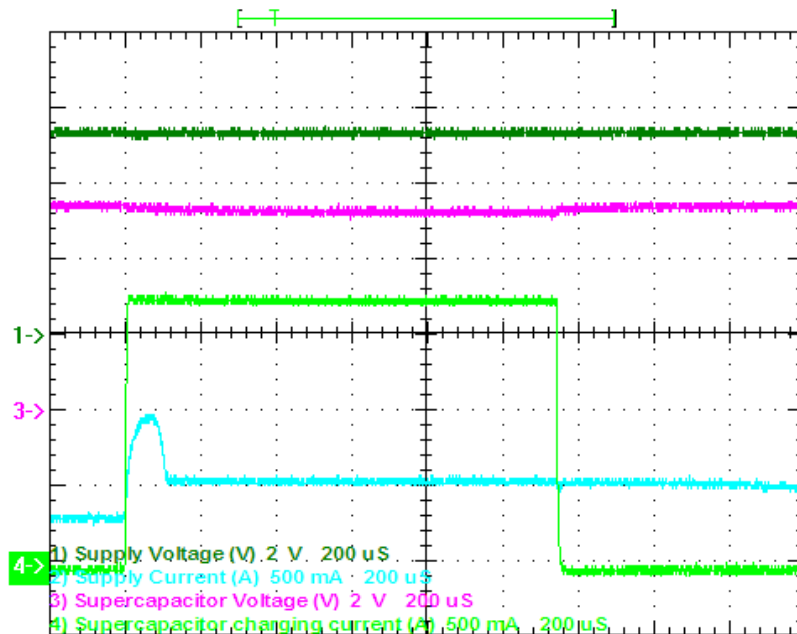

Figure 7: Load of a Class 10 GPRS pulse (1.8A) and a supercapacitor (0.12F and 50mΩ) with the supply at 5.5V and current limit set to 500mA (CAP-XX solution)

In the 5.5V applications with GPRS load, the 100μs supply current surge (peak of 950mA) can be taken care of by sufficient decoupling capacitors on the supply.

Thermal Limiting:

The CAP-XX solution has no thermal protection and care must be taken when using higher current limits. In the circuit shown in figure 1, R₂ (2k potentiometer) limits the maximum allowable current to 4.7Amps which is safe for the MOSFET. However if current limit higher than 4.7 Amps is required, R₂ must be changed according to the following calculation.

Maximum continuous drain current, I_d (for SUD45P03-10) = 12 A.

From the 'Safe Operating Area' graph below it can be seen that maximum DC power dissipation possible is about 4W.

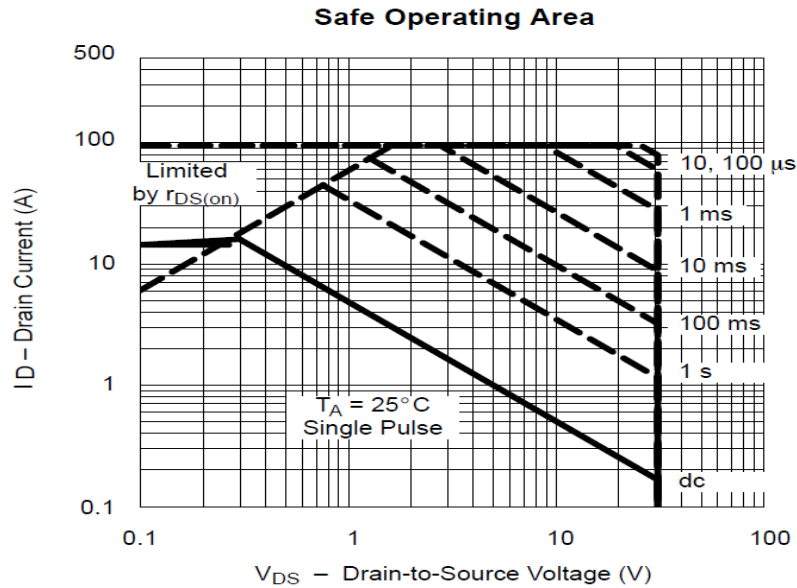

Figure 8: Safe operating area for the MOSFET, SUD45P03-10

For 4.5V operation, the R_{DS(ON)} = 18mΩ,

$$\begin{aligned} \text{Therefore, maximum } I_d &= \sqrt{\frac{\text{Maximum Power dissipation}}{R_{DS(ON)}}} \\ &= \sqrt{\frac{4}{0.018}} = 15\text{A.} \end{aligned}$$

However rise in temperature also increases R_{DS(ON)} thereby increasing power dissipation. Hence, safe maximum R_{DS(ON)} is rated as 12 Amps.

$$\text{Using equation 3 used previously, } i_{Lim} = \frac{R_2}{R_1(R_2 + R_6)} V_{D1}$$

$$\text{Rearranging it for } i_{Lim} \text{ of 12 Amps, we get: } 12 = \frac{R_2}{0.022(R_2 + 22,000)} \times 1.225$$

Therefore, R₂ = 6.04 kΩ for maximum current through the MOSFET, SUD45P03-10.

Reverse Current Blocking:

In certain applications, when the supply is turned OFF the engineers do not want the supercapacitor to discharge by supplying current to the source through the P-channel MOSFET's body diode. To avoid this, another P type FET can be connected in series with the existing MOSFET (M1) with its gate connected to gate of M3, source pin to the source of M1 and drain to sense resistor R1. As a result of this, when the J_ENABLE jumper is pulled off, both M1 and the new FET are turned off with their body diodes preventing current flow into the supply. However, this new MOSFET would add on to the present 40mΩ R_{DS(ON)}.

Alternative MOSFETS:

Name	RDS(ON) @ -4.5V (mΩ)	Absolute maximum I _d (A)
FDS7079ZN3	11.5 mΩ	-16 A
Si4825DY	22 mΩ	-8.1 A
IRF7410	7 mΩ	-16 A
IRF7420	14 mΩ	-11.5 A
IRF7329	17 mΩ	-9.2 A

Table 1: Alternative MOSFETs for the CAP-XX solution

Alternative Op-Amps:

Name	Minimum operating voltage (V)	Maximum operating voltage (V)	Slew Rate (V/μs)	Input offset voltage (μV)
AD8652	2.7 V	5.5 V	41 V/μs	Typically 100 μV
OPA2350	2.7V	5.5 V	22 V/μs	Typically 150 μV

Table 2: Alternative Op-Amps for the CAP-XX solution

Advantages and disadvantages of the CAP-XX solution

Advantages:

1. Works at 3V to 5.5V.
2. Fast settling time (10μs for charging a supercapacitor from 0V)
3. Adjustable current limit.
4. High current limit possible (max current depends on the MOSFET and the power rating of the sense resistor).
5. Low R_{DS(ON)} (Typically 40mΩ)

Disadvantages:

1. Numerous components therefore expensive.
2. External MOSFET.
3. Large space requirement.
4. No Thermal protection.
5. Another MOSFET required to prevent reverse current blocking.

Integrated Current Limit Solution

In recent years numerous high power portable devices especially those designed for PC card, CF card and USB application have entered the market. On the other hand this trend has not been complemented with high power portable batteries. In order to achieve optimum balance between power and run time, engineers have developed several battery management techniques including employing a CAP-XX supercapacitor in their solutions. The most crucial issue then is to control battery current during peak load and during charging the supercapacitor. As the devices are getting smaller in size, the demand of integrated current limit solutions is ever expanding. Currently available solutions have various features such as thermal protection, fast response, undervoltage lockout, reverse current blocking and programmable current limit. Nevertheless they have certain disadvantages too when compared to the CAP-XX solution such as higher impedance ranging from typically 65 mΩ to 145mΩ and inferior transient response.

AnalogicTech Solution: AAT 4610A

AnalogicTech's AAT4610A is a current limited load switch designed for high-side load switching with an operating voltage between 2.4V and 5.5V. The AAT4610A also employs thermal protection to avoid damage due to prolonged high current flow. AAT4610A comes in SOT23-5 and SC70JW-8 packages with a programmable current limit up to 1A_{max}. Unlike the CAP-XX solution, AAT4610 has a higher R_{DS(ON)} of typically 145mΩ to 190mΩ (at 5.0V and 3.0V respectively) and settling time of 20μsec.

Circuit Operation

Introduction

The AAT4610A current limiter as shown in figure 9 below has programmable current limit with a resistor from SET pin to ground with a maximum limit of 1A.

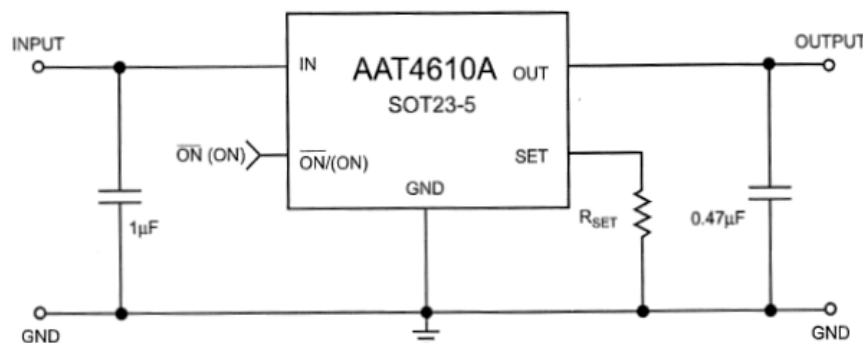

Figure 9: AAT4610 as used in a typical application

Functional Description

Setting current limit: To determine the value of R_{set}, start with the maximum current drawn by the load and multiply it by 1.33 (typical I_{lim} = minimum I_{lim}/0.75). This is the typical current limit value. Next, refer to "R_{set} vs. I_{lim}" table below and find the R_{set} that corresponds to the typical current limit value. Choose the largest resistor available that is less than or equal to it. The maximum current is derived by multiplying the typical current by 1.25 (adding the 25% variation due to manufacturing process, operating temperature and variation in the input and output voltage.).

R _{SET} (kΩ)	Current Limit Typ (mA)	Device will not current limit below (mA)	Device will always current limit below (mA)
40.2	200	150	250
30.9	250	188	313
24.9	300	225	375
22.1	350	263	438
19.6	400	300	500
17.8	450	338	563
16.2	500	375	625
14.7	550	413	688
13.0	600	450	750
10.5	700	525	875
8.87	800	600	1000
7.50	900	675	1125
6.81	1000	750	1250
6.04	1100	825	1375
5.49	1200	900	1500
4.99	1300	975	1625
4.64	1400	1050	1750

Table 3: Rset vs Ilim

For example: A USB port requires 500mA. 0.5A multiplied by 1.33 is 0.665A. Based on the R_{SET} vs I_{LIM} table above, RSET value of 11.0kΩ should be desirable. The next lower value to 11kΩ is 10.5kΩ and that would give a typical current value of 700mA. To find the upper and lower current limit values multiply 0.7A by 0.75 and 1.25. This means that the IC will limit current greater than 0.525A and less than 0.875A.

Transient Behaviour While Charging a Supercapacitor

Figure 10 and 11 below show the transient behaviour of the AAT4610A while charging a CAP-XX supercapacitor to 3.3V using a 1A current limit and to 5.5V with 500mA current limit.

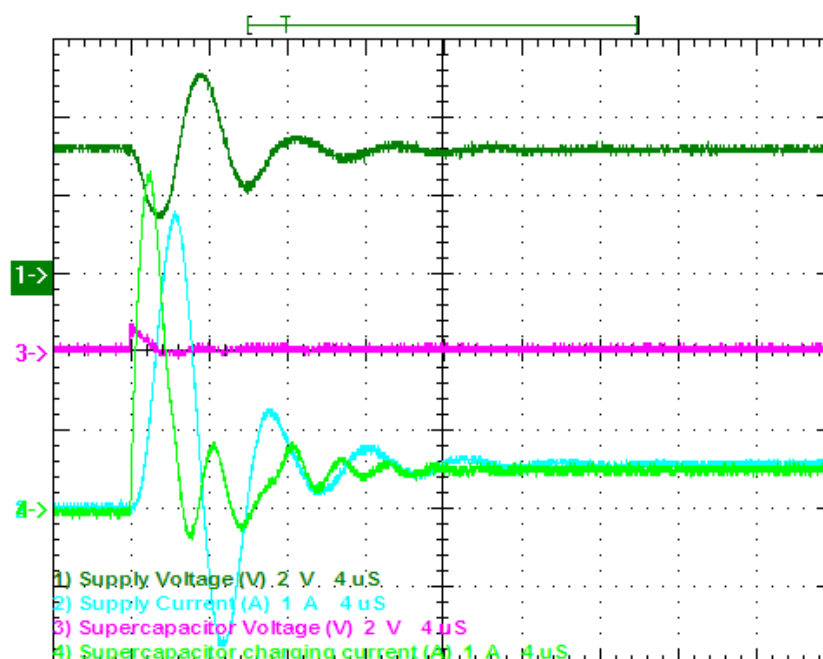

Figure 10: Charging a supercapacitor (0.12F and 50mΩ, initially at 0V) using 3.3V supply and the AAT4610A set to 1A current limit

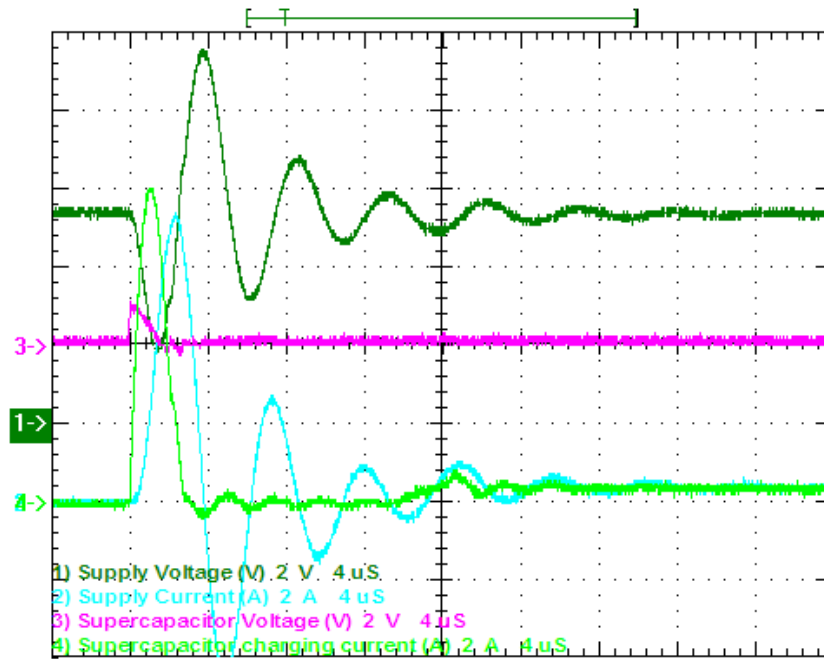

Figure 11: Charging a supercapacitor (0.12F and 50mΩ, initially at 0V) using 5.5V supply and the AAT4610A set to 500mA current limit

A host with sufficient decoupling capacitors could easily supply the required transient current.

Performance with Class 10 GPRS load

AAT4610A can also sufficiently control the input current limit when the load is a class 10 GPRS pulse at the supercapacitor. A class 10 GPRS pulse is 4.6msec long with 25% duty-cycle at 1.8Amps. The following graphs show the transient response of the currents and voltages with the GRPS load on the supercapacitor.

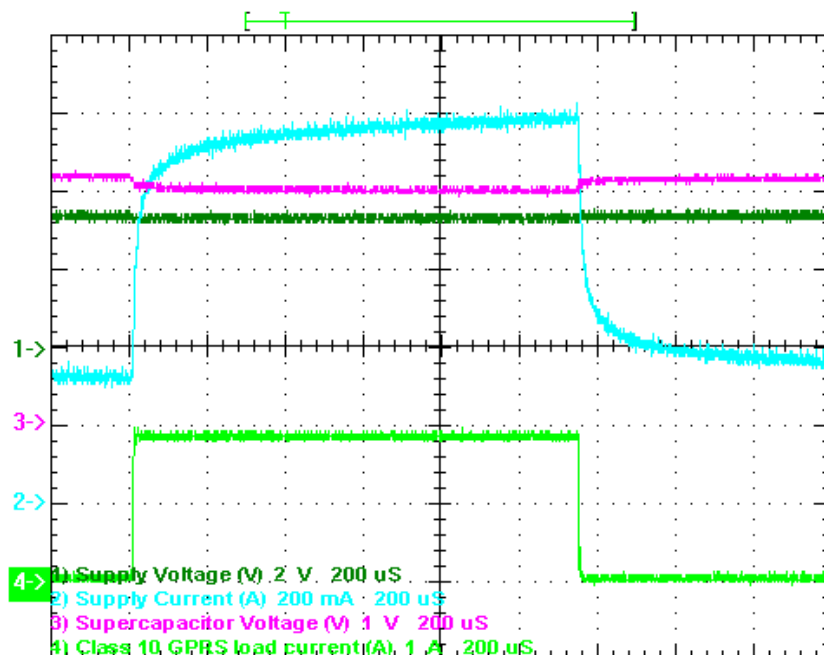

Figure 12: Load of a Class 10 GPRS pulse (1.8A) and a supercapacitor (0.12F and 50mΩ) with the supply at 3.3V and current limit of 1A set on the AAT4610A

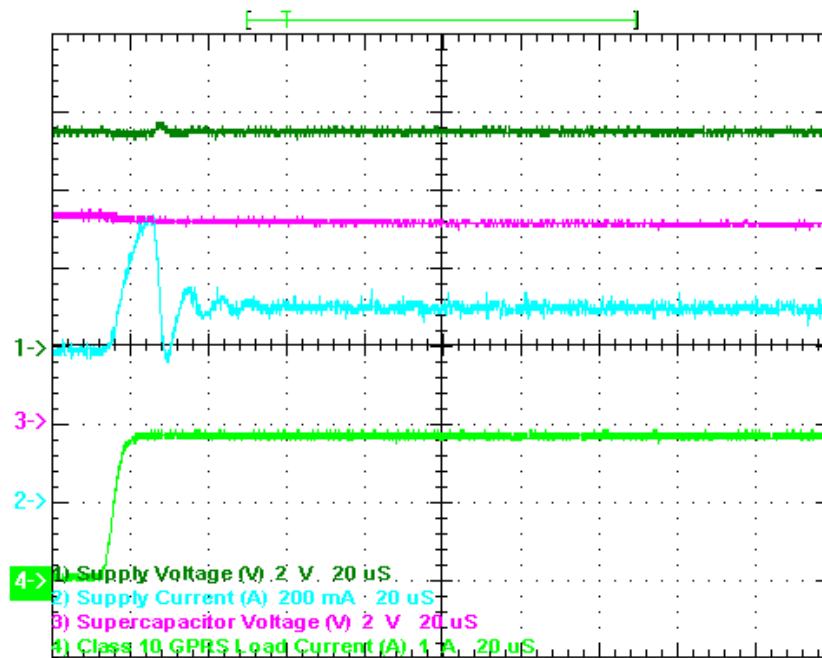

Figure 13: Load of a Class 10 GPRS pulse (1.8A) and a supercapacitor (0.12F and 50mΩ) with the supply at 5.5V and current limit of 500mA set on the AAT4610 (Transient)

Thermal limiting:

When a heavy load is applied to the output of AAT4610A that draws current higher than the I_{LIM} , the output voltage will drop resulting in dissipating higher than normal power and its die temperature to increase. Once the die temperature has exceeded the over-temperature limit, the IC shuts down until it has cooled down to a sufficient temperature, at which point it will start-up again.

Enable Input:

The enable on the AAT4610A has high and low threshold voltages that are compatible with 5V TTL and 2.5V to 5V CMOS.

Reverse Voltage:

The AAT4610A is designed to allow current flow from IN to OUT only. Applying a voltage at the OUT that is greater than the IN voltage could damage the IC.

Advantages and disadvantages of AAT4610A

Advantages:

1. Works at 2.4V to 5.5V.
2. Fast settling time (20μs to charge a supercapacitor)
3. Adjustable current limit.
4. Large current limit possible (up to 1A).
5. Small size.
6. No external MOSFET.
7. Over-temperature protection.

Disadvantages:

1. High R_{DS} (ON) of typically 145mΩ to 190mΩ (at 5.0V and 3.0V respectively).
2. Inaccurate current limit.
3. Does not limit current below 130mA.

Alternative Current Limit ICs:

Name	Minimum Operating Voltage (V)	Maximum Operating Voltage (V)	$R_{DS(ON)}$ (m Ω)	Minimum Current limit (mA)	Maximum Current limit (A)
AAT4618	2.4 V	5.5 V	125 m Ω	400mA fixed or 500mA fixed or 1000mA fixed	
AAT4620	3.0 V	5.5 V	65 m Ω @ 3.0V	100 mA	1200 mA
FPF2163	1.8 V	5.5 V	Typically 120 m Ω	150 mA	1500 mA
SiP4610A/B	2.4 V	5.5 V	145 m Ω @ 5V	130 mA	1000mA
TPS2551	2.5 V	6.5 V	85 m Ω	100 mA	1100 mA

Further Information

CAP-XX will be pleased to provide further information on the applications described here, and on the use of supercapacitors in any application. Please use the contact details provided on the CAP-XX web site (www.cap-xx.com).

This Application Note is available on the cap-XX web site. On the web site you may also find product bulletins, datasheets, SPICE models, application notes, application briefs and design-aid calculator (<http://cap-xx.com/resources/resources.htm>).